

Aspects of Technology

A s s e s s m e n t R e s u l t s 2 0 0 8

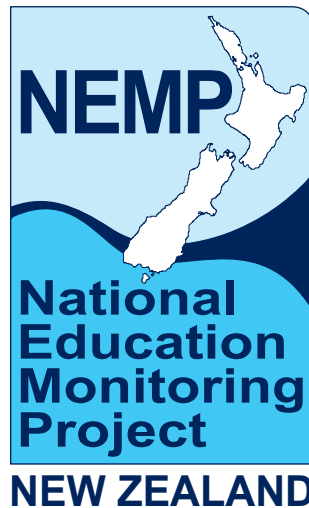



Aspects of Technology

Assessment Results

2008

Jeffrey Smith
Terry Crooks
Ros Allan

with extensive assistance from
other members of the EARU team:

Lester Flockton, Emeritus Director

and

Lee Baker
Linda Doubleday
Corryl Harper
Madgerie Jameson
Lynette Jones
James Rae
Pamala Walrond
Jane White

EARU

**NATIONAL EDUCATION MONITORING
REPORT 48**



MINISTRY OF EDUCATION

Te Tāhuhu o te Mātauranga

© 2009 Ministry of Education, New Zealand

NEMP REPORTS

CYCLE 1

1995 1 Science
2 Art
3 Graphs, Tables and Maps

1996 4 Music
5 Aspects of Technology
6 Reading and Speaking

1997 7 Information Skills
8 Social Studies
9 Mathematics

1998 10 Listening and Viewing
11 Health and Physical Education
12 Writing

CYCLE 2

1999 13 Science
14 Art
15 Graphs, Tables and Maps
16 Māori Students' Results

2000 17 Music
18 Aspects of Technology
19 Reading and Speaking
20 Māori Students' Results

2001 21 Information Skills
22 Social Studies
23 Mathematics
24 Māori Students' Results

2002 25 Listening and Viewing
26 Health and Physical Education
27 Writing
28 Māori Students' Results

CYCLE 3

2003 29 Science
30 Visual Arts
31 Graphs, Tables and Maps
42 Māori Medium Students' Results

2004 32 Music
33 Aspects of Technology
34 Reading and Speaking
43 Māori Medium Students' Results

2005 35 Information Skills
36 Social Studies
37 Mathematics
38 Māori Medium Students' Results

2006 39 Listening and Viewing
40 Health and Physical Education
41 Writing

CYCLE 4

2007 44 Science
45 Visual Arts
46 Graphs, Tables and Maps

2008 47 Music
48 Aspects of Technology
49 Reading and Speaking

2009 Information Skills for Inquiry Learning
Social Studies
Mathematics and Statistics

2010 Listening and Viewing
Health and Physical Education
Writing

Note that reports are published the year after the research is undertaken
i.e. reports for 2009 will not be available until 2010.



EDUCATIONAL ASSESSMENT RESEARCH UNIT

PO Box 56, Dunedin, New Zealand

Tel: 0800 808 561 Fax: 64 3 479 7550

Email: earu@otago.ac.nz

Web: <http://nemp.otago.ac.nz>

Contents

- 2 Acknowledgements
- 3 Summary
- 5 Chapter 1 : The National Education Monitoring Project
- 9 Chapter 2 : Assessing Technology

13 Chapter 3 : Technological Knowledge and Understanding

trend:

- 14 Fishing Game
- 16 The Crafty Knife
- 17 Cookie Time
- 18 Bags
- 19 Food for Tramping

links:

- 20 Link Tasks 1–4

21 Chapter 4 : Technological Capability

trend:

- 22 A Bit of a Lemon
- 23 Exercising Rats
- 26 Eel Trap
- 27 Shell Container

released:

- 30 Class Furniture

links:

- 31 Link Tasks 5–10

32 Chapter 5 : Technology and Society

trend:

- 33 Fishing
- 34 Changes Over Time
- 35 Pizza Survey
- 36 Toys
- 38 Whirligigs

links:

- 39 Link Tasks 11–14

-
- 40 Chapter 6 : Technology Survey
 - 43 Chapter 7 : Performance of Subgroups
 - 47 Appendix : The Sample of Schools and Students in 2008
 - 50 Resource Acknowledgements

NATIONAL EDUCATION MONITORING REPORT 48

This report was prepared and published by the Educational Assessment Research Unit, University of Otago, New Zealand, under contract to the Ministry of Education, New Zealand.

ISSN 1174-0000 ISBN 1-877182-76-1

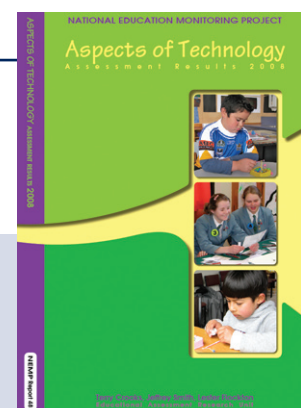

A Acknowledgements

The Project directors acknowledge the vital support and contributions of many people to this report, including:

- ▶ the very dedicated staff of the Educational Assessment Research Unit
- ▶ Heleen Visser, Hadyn Green and other staff members of the Ministry of Education
- ▶ members of the Project's National Advisory Committee
- ▶ members of the Project's Technology Advisory Panel
- ▶ principals and children of the schools where tasks were trialled
- ▶ principals, staff and Board of Trustee members of the 246 schools included in the 2008 sample
- ▶ the 2867 children in the samples for the assessments, and their parents
- ▶ the 96 teachers who administered the assessments to the children
- ▶ the 43 senior tertiary students who assisted with the marking process
- ▶ the 192 teachers who assisted with the marking of tasks early in 2009
- ▶ the people and organisations who granted permission for the publication of their work in this report, to illustrate our assessment resources (acknowledged in full on page 50).

Overview: The 2008 Technology results show that technology is a highly popular subject area, particularly among year 8 students. Students enjoy making things in school and, at year 8, learning how to use tools. There is moderate growth from year 4 to year 8 in most technology tasks, with stronger gains seen in areas that require generating a design, or looking at broader societal and family concerns of the impact of technology. Gender differences tend to “average out” with students typically doing better with tasks traditionally linked to their gender. Pakeha/Māori differences and Pakeha/Pasifika differences remained in the moderate to large range, with no discernible trends seen over time. Socio-economic status remained a strong predictor of performance at the school level, with the other school variables showing only a minor influence on results.



New Zealand’s National Education Monitoring Project commenced in 1993, with the task of assessing and reporting on the achievement of New Zealand primary school children in all areas of the school curriculum. Children are assessed at two class levels: year 4 (halfway through primary education) and year 8 (at the end of primary education). Different curriculum areas and skills are assessed each year, over a four-year cycle. The main goal of national monitoring is to provide detailed information about what children know, think and can do, so that patterns of performance can be recognised, successes celebrated, and desirable changes to educational practices and resources identified and implemented.



Each year, random samples of children are selected nationally, then assessed in their own schools by teachers specially seconded and trained for this work. Task instructions are given orally by teachers, through video presentations, on laptop computers, or in writing. Many of the assessment tasks involve the children in the use of equipment and materials. Their responses are presented orally, by demonstration, in writing, in computer files, or through submission of other physical products. Many of the responses are recorded on videotape for subsequent analysis.

The use of many tasks with both year 4 and year 8 students allows comparisons of the performance of years 4 and 8 students in 2008. Because about 45% of the tasks have been used twice, in 2004 and again in 2008, trends in performance across the four-year period can also be analysed.

In considering the analyses, it should be kept in mind that a large number of questions in technology asked students to think of all the ideas they had on a subject, such as all the ways a product could be improved. We coded a wide variety of responses, and then tallied the number of students providing those responses. This process leads to the inclusion of a large number of responses with fairly low frequencies. As a result, at times it may look like students are not doing well because the number of responses given is often not a large percentage of the number of options available. These percentages should not be interpreted in any way as “percent correct”. They are simply the percentage of students who thought of a particular response.



ASSESSING TECHNOLOGY

In 2008, the second year of the fourth cycle of national monitoring, three areas were assessed: music, aspects of technology, and reading and speaking. This report presents details and results of the assessments of aspects of technology.



Technology is a creative, purposeful activity aimed at meeting needs and opportunities through the development of products, systems or environments.

Knowledge, skills and resources are combined to help solve practical problems in particular social contexts.

A framework for technology education and its assessment is presented in Chapter 2. The framework highlights the three strands of the New Zealand technology curriculum:

- technological knowledge and understanding;
- technological capability;
- understanding and awareness of the relationship between technology and society.

Technology is a multidisciplinary activity. To attempt to represent all or even most of the areas, meanings and applications of technology within the national monitoring assessment programme would be unrealistic. After careful examination of the scope of the technology curriculum, it was decided to assess some key aspects, with a particular focus on the knowledge, understandings and skills listed above. Selected areas of content and broadly overlapping contexts (e.g. personal, home, school, community) have been used to investigate the ideas students have and the processes they can use.

TECHNOLOGICAL KNOWLEDGE AND UNDERSTANDING

Chapter 3 looks at student knowledge and understanding of technology, and is assessed through the use of nine tasks. Substantial growth was seen from year 4 to year 8 on most, but not all, tasks. Generally speaking, year 8 students were able to provide more details when questioned about aspects of objects, and were able to provide better explanations of their ideas. There were 91 separate task components asked of students

at both year 4 and year 8, with year 8 students providing correct or strong responses 41% of the time and year 4 students doing so 32% of the time.

There was almost no change in performance in this area from the 2004 NEMP administration. All five of the tasks presented in detail in this chapter include data from the 2004 administration of NEMP. At year 4, there

were 52 task components administered with 2008 students providing correct or strong responses 29% of the time. The comparable figure for 2004 was 30%. At year 8, there were 73 task components that could be compared. Here the 2008 performance was 38% and the 2004 performance was also 38%.



TECHNOLOGICAL CAPABILITY

The area of technological capability (Chapter 4) primarily involves the issues of generating and evaluating designs for objects. Students show substantial growth from year 4 to year 8 in terms of technological capability. This is particularly true when students have to generate a design, more so than when they are asked to evaluate an existing design. There were a total of 90 task components administered to year 4 and year 8 students. On average, year 4 students provided correct or strong responses 36% of the time, whereas year 8 students were successful 48% of the time.

The results show a small decline in performance at both year 4 and year 8 from the 2004 NEMP administration. There were 35 tasks administered to both 2004 and 2008 samples at year 4, with 2008 students providing strong or correct responses 27% of the time. The corresponding figure for 2004 is 31%. At year 8, there are 42 task components in common; 2008 students were successful 38% of the time compared to 40% for the 2004 students. At both years, the decrease is fairly small.



TECHNOLOGY SURVEY

Technology is highly popular with students at both years, but more so at year 8. The results here are consistent with the findings over the years in NEMP reports that for year 8 students, only physical education is a more popular subject area. The survey results also show that there is an increase in the use of tools and in the actual designing and making of objects in school at year 8 (as compared to year 4). However, the construction of objects in the home at year 8 shows a decline from 2004, with a concomitant rise in the use of computers.



TECHNOLOGY AND SOCIETY

Chapter 5 looks at student responses to tasks that asked students to consider the societal issues and concerns associated with technology. There are substantial gains made in performance from year 4 to year 8, particularly in areas that require students to think more broadly about societal aspects of technology. There were 141 components of tasks that were administered to year 4 and year 8 students. Year 4 students provided correct or strong responses to 24% of these task components, compared to 36% for year 8 students.



There was a slight decline in performance from 2004 to 2008 for the year 4 students, but no change for the year 8 students. Averaged across 104 task components, 26% of year 4 students in 2008 gave correct or strong responses, compared to 29% in 2004. This represents a slight decrease in performance overall. At year 8, both groups were successful on 38% of the tasks.

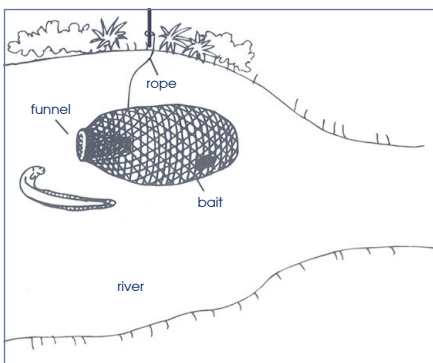

OVERALL TRENDS

Overall trends can be assessed by considering all trend tasks from Chapters 3 to 5. For year 4 students, based on 191 task components, on average, 3% fewer students than in 2004 succeeded with the task components in 2008. As can be seen above, the downward trend was consistent across all three chapters. For year 8 students, based on 219 task components, on average, there was no difference between 2004 and 2008

PERFORMANCE OF SUBGROUPS

Using total scores for each of the tasks, we are able to look at subgroup performance for both school and individual levels.

At the school level, the most important factor in terms of relationship to performance is socio-economic status (SES). Students in high decile schools consistently outperform students in low decile schools; students in schools in the middle decile range more often have scores closer to the high decile schools. This pattern tends to occur across all areas that are studied by NEMP. The other school level variables (school size, community size, zone, and type of school) tend to only have modest relationships with performance.

At the individual level, there are minimal gender effects, but moderate to large effects for Pakeha/Māori differences, Pakeha/Pasifika differences and for the predominant language spoken in the home, English, or otherwise. Pakeha students receive higher marks than Māori or Pasifika students and students whose home language is English receive higher marks than students whose home language is not English.



The National Education Monitoring Project

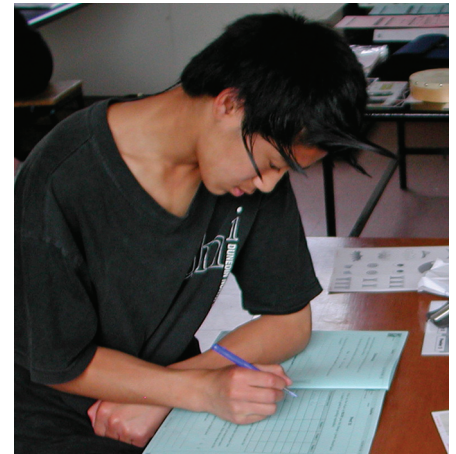

This chapter presents a concise outline of the rationale and operating procedures for national monitoring, together with some information about the reactions of participants in the 2008 assessments. Detailed information about the sample of students and schools is available in the Appendix.

Purpose of National Monitoring

The New Zealand Curriculum Framework (1993, p26) states that the purpose of national monitoring is to provide information on how well overall national standards are being maintained, and where improvements might be needed.

The focus of the National Education Monitoring Project (NEMP) is on the educational achievements and attitudes of New Zealand primary and intermediate school children. NEMP provides a national “snapshot” of children’s knowledge, skills and motivation, and a way to identify which aspects are improving, staying constant or declining. This information allows successes to be celebrated and priorities for curriculum change and teacher development to be debated more effectively, with the goal of helping to improve the education which children receive.

Assessment and reporting procedures are designed to provide a rich picture of what children can do and thus to optimise value to the educational community. The result is a detailed national picture of student achievement. It is neither feasible nor appropriate, given the purpose and the approach used, to release information about individual students or schools.

Monitoring at Two Class Levels

National monitoring assesses and reports what children know and can do at two levels in primary and intermediate schools: year 4 (ages 8-9) and year 8 (ages 12-13).

National Samples of Students

National monitoring information is gathered using carefully selected random samples of students, rather than all year 4 and year 8 students. This enables a relatively extensive exploration of students’ achievement, far more detailed than would be possible if all students were to be assessed. The main national samples of 1440 year 4 children and 1440 year 8 children represent about 2.5% of the children at those levels in New Zealand schools, large enough samples to give a trustworthy national picture.

Three Sets of Tasks at Each Level

So that a considerable amount of information can be gathered without placing too many demands on individual students, different students attempt different tasks. The 1440 students selected in the main sample at each year level are divided into three groups of 480 students, comprising four students from each of 120 schools. Each group attempts one third of the tasks.

YEAR		NEW ZEALAND CURRICULUM	Communication skills Problem-solving skills Self-management and competitive skills Social and cooperative skills Work and study skills	Attitudes
1	2007 (2003) (1999) (1995)	Science Visual Arts Information Skills: <i>graphs, tables, maps, charts & diagrams</i>		
2	2008 (2004) (2000) (1996)	Language: <i>reading and speaking</i> Aspects of Technology Music		
3	2009 (2005) (2001) (1997)	Mathematics and Statistics: <i>numeracy skills</i> Social Studies Information Skills for Inquiry Learning: <i>library, research</i>		
4	2010 (2006) (2002) (1998)	Language: <i>writing, listening, viewing</i> Health and Physical Education		

Timing of Assessments

The assessments take place in the second half of the school year, between August and November. The year 8 assessments occur first, over a five-week period. The year 4 assessments follow, over a similar period. Each student participates in about four hours of assessment activities spread over one week.

Specially Trained Teacher Administrators

The assessments are conducted by experienced teachers, usually working in their own region of New Zealand. They are selected from a national pool of applicants, attend a week of specialist training in Wellington led by senior Project staff and then work in pairs to conduct assessments of 60 children over five weeks. Their employing school is fully funded by the Project to employ a relief teacher during their secondment.

Four-Year Assessment Cycle

Each year, the assessments cover about one quarter of the areas within the national curriculum for primary schools. The New Zealand Curriculum Framework is the blueprint for the school curriculum. It places emphasis on seven essential learning areas, eight essential skills and a variety of attitudes and values. National monitoring aims to address all of these areas, rather than restrict itself to pre-selected priority areas.

The first four-year cycle of assessments began in 1995 and was completed in 1998. The second cycle ran from 1999 to 2002.

The third cycle began in 2003 and finished in 2006. The fourth cycle began in 2007. The areas covered each year and the reports produced are listed opposite the contents page of this report.

Approximately 45% of the tasks are kept constant from one cycle to the next. This re-use of tasks allows trends in achievement across a four-year interval to be observed and reported.

Important Learning Outcomes Assessed

The assessment tasks emphasise aspects of the curriculum which are particularly important to life in our community, and which are likely to be of enduring importance to students. Care is taken to achieve balanced coverage of important skills, knowledge and understandings within the various curriculum strands, but without attempting to follow slavishly the finer details of current curriculum statements. Such details change from time to time, whereas national monitoring needs to take a long-term perspective if it is to achieve its goals.

Wide Range of Task Difficulty

National monitoring aims to show what students know and can do. Because children at any particular class level vary greatly in educational development, tasks spanning multiple levels of the curriculum need to be included if all children are to enjoy some success and all children are to experience some challenge. Many tasks include several aspects, progressing from aspects most children can handle well to aspects that are less straightforward.

Engaging Task Approaches

Special care is taken to use tasks and approaches that interest students and stimulate them to do their best. Students' individual efforts are not reported and have no obvious consequences for them. This means that worthwhile and engaging tasks are needed to ensure that students' results represent their capabilities rather than their level of motivation. One helpful factor is that extensive use is made of equipment and supplies which allow students to be involved in hands-on activities. Presenting some of the tasks on video or computer also allows the use of richer stimulus material, and standardises the presentation of those tasks.



Positive Student Reactions to Tasks

At the conclusion of each assessment session, students completed evaluation forms in which they identified tasks that they particularly enjoyed, tasks they felt relatively neutral about and tasks that did not appeal. Averaged across all tasks in the 2008 assessments, 74% of year 4 students indicated that they particularly enjoyed the tasks. The range across the 104 tasks was from 95% down to 40%. As usual, year 8 students were more demanding. On average, 61% of them indicated that they particularly enjoyed the tasks, with a range across 119 tasks from 92% down to 31%. Four tasks were more disliked than liked, by year 8 students only: a unison team singing task, a task involving reading in te reo Māori, a reading comprehension task and a task involving evaluating furniture designs.

Appropriate Support for Students

A key goal in Project planning is to minimise the extent to which student strengths or weaknesses in one area of the curriculum might unduly influence their assessed performance in other areas. For instance, skills in reading and writing often play a key role in success or failure in paper-and-pencil tests in areas such as science, social studies, or even mathematics. In national monitoring, a majority of tasks are presented orally by teachers, on video, or on computer, and most answers are given orally or by demonstration rather than in writing. Where reading or writing skills are required to perform tasks in areas other than reading and writing, teachers are happy to help students to understand these tasks or to communicate their responses. Teachers are working with no more than four students at a time, so are readily available to help individuals.

To free teachers further to concentrate on providing appropriate guidance and help to students, so that the students achieve as well as they can, teachers are not asked to record judgements on the work the students are doing. All marking and analysis is done later, when the students' work has reached the Project office in Dunedin. Some of the work comes on paper, but much of it arrives recorded on videotape. In 2008, about 65% of the students' work came in that form, on a total of about 4200 videotapes. The video recordings give a detailed picture of what students and teachers did and said, allowing rich analysis of both process and task achievement.

Four Task Approaches Used

In 2008, four task approaches were used. Each student was expected to spend about an hour working in each format. The four approaches were:

- *One-to-one interview*
Each student worked individually with a teacher, with the whole session recorded on videotape.
- *Stations*
Four students, working independently, moved around a series of stations where tasks had been set up. This session was not videotaped.
- *Group and Independent*
Four students worked collaboratively, supervised by a teacher, on some tasks. This was recorded on videotape. The students then worked individually on some paper-and-pencil tasks.
- *Team*
Four students worked collaboratively, supervised by a teacher, on some tasks. This was recorded on videotape.



Professional Development Benefits for Teacher Administrators

The teacher administrators reported that they found their training and assessment work very stimulating and professionally enriching. Working so closely with interesting tasks administered to 60 children in at least five schools offered valuable insights. Some teachers have reported major changes in their teaching and assessment practices as a result of their experiences working with the Project. Given that 96 teachers served as teacher administrators in 2008, or about 0.5% of all primary teachers, the Project is making a major contribution to the professional development of teachers in assessment knowledge and skills. This contribution will steadily grow, since preference for appointment each year is given to teachers who have not previously served as teacher administrators. The total after 14 years is 1298 different teachers, 90 of whom have served more than once.

Marking Arrangements

The marking and analysis of the students' work occurs in Dunedin. The marking process includes extensive discussion of initial examples and careful checks of the consistency of marking by different markers.

Tasks which can be marked objectively or with modest amounts of professional experience usually are marked by senior tertiary students, most of whom have completed two or three years of pre-service preparation for primary school teaching. Forty-four student markers worked on the 2008 tasks, employed five hours per day for about four weeks.

The tasks that require higher levels of professional judgement are marked by teachers, selected from throughout New Zealand. In 2008, 200 teachers were appointed as markers. Most teachers worked either mornings or afternoons for one week. Teacher professional development through participation in the marking process is another substantial



benefit from national monitoring. In evaluations of their experiences on a four-point scale (“dissatisfied” to “highly satisfied”), 63% to 90% of the teachers who marked student work in January 2009 chose “highly satisfied” in response to questions about:

- the instructions and guidance given during marking sessions
- the degree to which marking was professionally satisfying and interesting
- its contribution to their professional development in the area of assessment
- the overall experience.

Analysis of Results

The results are analysed and reported task by task. Most task reports include a total score, created by adding scores for appropriate task components. Details of how the total score has been constructed for particular assessment tasks can be obtained from the NEMP office (earu@otago.ac.nz).



Although the emphasis is on the overall national picture, some attention is also given to possible differences in performance patterns for different demographic groups and categories of school. The variables considered are:

- **Student gender:**
 - male
 - female
- **Student ethnicity:**
 - Māori
 - Pasifika
 - Pakeha (includes all other students)
- **Home language:** (predominant language spoken at home)
 - English
 - any other language
- **Geographical zone:**
 - Greater Auckland
 - other North Island
 - South Island
- **Size of community:**
 - main centre over 100,000
 - provincial city of 10,000 to 100,000
 - rural area or town of less than 10,000



- **Socio-economic index for the school:**
 - lowest three deciles
 - middle four deciles
 - highest three deciles
- **Size of school:**
 - YEAR 4 SCHOOLS
 - less than 25 year-4 students
 - 25 to 60 year-4 students
 - more than 60 year-4 students
 - YEAR 8 SCHOOLS
 - less than 35 year-8 students
 - 35 to 150 year-8 students
 - more than 150 year-8 students
- **Type of school:** (for year 8 sample only)
 - full primary school
 - intermediate school
 - year 7–13 high school
 (some students were in other types of schools, but too few to allow separate analysis).

Categories containing fewer children, such as Asian students or female Māori students, were not used because the resulting statistics would be based on the performance of fewer than 70 children, and would therefore be unreliable.

An exception to this guideline was made for Pasifika children and children whose home language was not English because of the agreed importance of gaining some information about their performance.

Funding Arrangements

National monitoring is funded by the Ministry of Education, and organised by the Educational Assessment Research Unit at the University of Otago, under the direction of Professors Terry Crooks and Jeffrey Smith. The current contract runs until 2010. The cost is about \$2.7 million per year, less than one tenth of a percent of the budget allocation for primary and secondary education. Almost half of the funding is used to pay for the time and expenses of the teachers who assist with the assessments as task developers, teacher administrators or markers.

Reviews by International Scholars

In June 1996, three scholars from the United States and England, with distinguished international reputations in the field of educational assessment, accepted an invitation from the Project directors to visit the Project. They conducted a thorough review of the progress of the Project, with particular attention to the procedures and tasks used in 1995 and the results emerging. At the end of their review, they prepared a report which concluded as follows:

The National Education Monitoring Project is well conceived and admirably implemented. Decisions about design, task development, scoring and reporting have been made thoughtfully. The work is of exceptionally high quality and displays considerable originality. We believe that the project has considerable potential for advancing the understanding of and public debate about the educational achievement of New Zealand students. It may also serve as a model for national and/or state monitoring in other countries.

(Professors Paul Black, Michael Kane & Robert Linn, 1996)

A further review was conducted late in 1998 by another distinguished panel (Professors Elliot Eisner, Caroline Gipps and Wynne Harlen). Amid very helpful suggestions for further refinements and investigations, they commented that:

We want to acknowledge publicly that the overall design of NEMP is very well thought through... The vast majority of tasks are well designed, engaging to students and consistent with good assessment principles in making clear to students what is expected of them.

Further Information

A more extended description of national monitoring, including detailed information about task development procedures, is available in:

Flockton, L. (1999). *School-wide Assessment: National Education Monitoring Project*. Wellington: New Zealand Council for Educational Research.

2 Assessing Technology



Technology is a universal and age-old human activity... The technologies used today have built on the ingenuity, traditions, observation and knowledge of people who, throughout history, have sought to improve their lives, solve problems and satisfy their needs and wants.

Technology in the New Zealand Curriculum (1995)

Technology in the New Zealand Curriculum

Technology became a learning area in its own right with the formulation of the *New Zealand Curriculum Framework* (1993) and the introduction of the national curriculum statement, *Technology in the New Zealand Curriculum* (1995). Technology is defined in the curriculum statement as:

... a creative, purposeful activity aimed at meeting needs and opportunities through the development of products, systems, or environments. Knowledge, skills and resources are combined to help solve practical problems. Technological practice takes place within, and is influenced by, social contexts.

Technology in the New Zealand Curriculum (1995, p6)

Aim of Technology Education

The three-fold aim of technology education in the national curriculum is to enable students to achieve technological literacy through the development of:

- technology knowledge and understanding;
- understanding and awareness of the relationship between technology and society;
- technological capability.

The three parts of the aim are interrelated; the intention is that they should be treated holistically rather than as three separate entities. For national monitoring purposes, the three parts provide a useful basis for an assessment framework.

The third aim, technology capability, recognises that technology is a multi-disciplinary process. This process is developed through problem-solving activities which involve designing, making, modifying, evaluating and reflecting.

Technological Knowledge, Understandings and Skills

Technology education is broad in its scope, yet quite focussed in the ways that knowledge, understandings and skills are acquired and used.

Technology education in the New Zealand curriculum is specifically about:

- investigating, using and understanding technologies;
- gaining knowledge of technological principles and processes;
- exploring needs and opportunities that could benefit from creative and scientific technological activity;
- creating, designing, planning, trying and evaluating ideas to improve or modify existing products and processes;
- using materials, tools and equipment skilfully and safely;
- recognising the connections between technology and society in time and place.

ASPECTS OF TECHNOLOGY FRAMEWORK 2008

CENTRAL ORGANISING THEME

Understanding, using, developing and critiquing technology and its outcomes in personal and social contexts within local and global environments.

KNOWLEDGE, UNDERSTANDINGS AND VALUES

- Ways in which technologies develop
- Interactions between technology and society in time and place
- Relationships between physical and functional characteristics of technological outcomes
- Product analysis and evaluation to determine fitness for purpose
- Properties and characteristics of materials
- Components and processes of systems
- Modeling to test design ideas (functional modeling) and technological outcomes (prototyping)

ABILITIES AND SKILLS

- Identifying and refining needs and opportunities for technological practice
- Generating possible solutions and related strategies
- Identifying, selecting, developing and/or adapting design ideas and solutions
- Managing resources (e.g. time, materials and people)
- Critically evaluating decisions, strategies, outcomes and consequences, taking into account conflicting demands
- Communicating decisions, strategies, outcomes and consequences (both actual and potential)
- Investigating and evaluating design ideas and technologies
- Technical skills and techniques
- Use of technological language

MOTIVATION

- Enthusiasm for knowing about and exploring technology
- Voluntary engagement in technology activities
- Confidence and willingness to try new ideas
- Perceptions about appropriate and inappropriate uses of technology

Areas of Technology

The areas of technology within which students develop their knowledge, understandings and skills embrace a great deal of personal, cultural, environmental and economic activity. Biotechnology, for example, involves the use of living systems and organisms; materials technology includes the investigation, use and development of materials such as wood, textiles, metals and fuels; information and communication technology covers a complex range of processes, equipment and devices that enable the management and use of numerous forms of data and information.

Design, including the processes of specification, development and testing of ideas, is central to all areas of technology. In technology education students plan, make, modify, maintain, use, evaluate and improve products, systems and environments.

Aspects of Technology Investigated by National Monitoring

Technology is a multidisciplinary activity. Its extensive cross-curricular possibilities reflect its vast pervasiveness throughout the world in which we learn and live as individuals, groups and societies. To attempt to represent all or even most of the areas, meanings and applications of technology within the national monitoring assessment programme would be unrealistic.

After careful examination of the scope of the technology curriculum, it was decided to assess some key aspects, with a particular focus on the knowledge,

understandings and skills listed above. Selected areas of content and broadly overlapping contexts (e.g. personal, home, school, community) have been chosen as means to investigating the processes students use and the ideas they have. For national monitoring purposes, it is neither necessary nor practically possible to cover every area of content or all major contexts.

Framework for National Monitoring Assessment

National monitoring task frameworks are developed by the Project's curriculum advisory panels. These frameworks have two key purposes. They provide a valuable guideline structure for the development and selection of tasks, and they bring into focus those important dimensions of the learning domain that should be included for valid analyses of students' skills, knowledge and understandings.

The frameworks are organising tools which interrelate content with strategies, skills and processes. They are intended to be flexible and broad enough to encourage and enable the development of tasks that lead to meaningful descriptions of what students know and can do. They also provide help to ensure a balanced representation of important learning outcomes.

The technology framework has a central organising theme supported by three interrelated aspects.

The *theme*, "Knowing about technology in society and using opportunities to solve technological problems and meet needs in contexts appropriate to students'

worlds of experience", is consistent with New Zealand's technology curriculum and sets the broad context for tasks.

The aspects titled *Knowledge, Understandings and Values* and *Abilities and Skills* highlight the learning that students could be expected to demonstrate while engaged with the *Areas of Content*. The knowledge, understandings, values, abilities and skills are highly interrelated both within each aspect and across the total framework.

The *Motivation* aspect of the framework directs attention to the importance of having information about students' technological interests, attitudes, confidence and involvement, both within and beyond the school setting. Educational research and practice confirm the impact of student motivation and attitudes on achievement and learning outcomes.

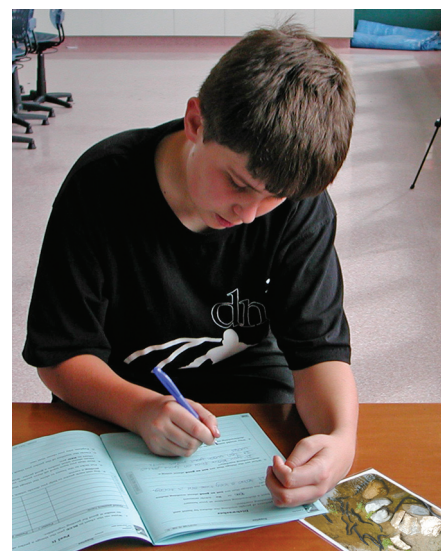

The Choice of Technology Tasks for National Monitoring

The choice of technology tasks for national monitoring is guided by a number of educational and practical considerations. Uppermost in any decisions relating to the choice or administration of a task is the central consideration of validity and the effect that a whole range of decisions can have on this key attribute. Tasks are chosen because they provide a good representation of important dimensions of technology education, but also because they meet a number of requirements to do with their administration and presentation. For example:

- Each task with its associated materials needs to be structured to ensure a high level of consistency in the way it is presented by specially trained teacher administrators to students of wide-ranging back-grounds and abilities, and in diverse settings throughout New Zealand.
- Tasks need to span the expected range of capabilities of year 4 and 8 students and to allow the most able students to show the extent of their abilities while also giving the least able the opportunity to show what they can do.
- Materials for tasks need to be sufficiently portable, economical, safe and within the handling capabilities of students. Viewing and listening components need to be chosen to have meaning for students.
- The time needed for completing an individual task has to be balanced against the total time available for all of the assessment tasks, without denying students sufficient opportunity to demonstrate their capabilities.
- Each task needs to be capable of sustaining the attention and effort of students if they are to produce responses that truly indicate what they know and can do. Since neither the student nor the school receives immediate or specific feedback on performance, the motivational potential of the assessment is critical.
- Tasks need to avoid unnecessary bias on the grounds of gender, culture or social background while accepting that it is appropriate to have tasks that reflect the interests of particular groups within the community.

National Monitoring Technology Assessment Tasks and Survey

Twenty-nine technology tasks were administered. Students also completed an interview questionnaire that investigated their attitudes towards, conceptions of, and involvement in technology activity.

Eleven tasks were administered in one-to-one interview settings, where students used materials and visual information. Six tasks were presented in team or group situations involving small groups of students working together. Eleven tasks were attempted in a stations arrangement, where students worked independently on a series of tasks. Finally, one task was presented in an independent approach, where four students worked on the same tasks at the same time, independently.

Twenty-two of the 29 tasks were the same or almost the same for both year 4 and 8. Seven tasks were attempted only by year 8 students.

Trend Tasks

Fourteen of the tasks in this report were previously used in identical form in the 2004 technology assessments. These were called *link tasks* in the 2004 report, but were not described in detail to avoid any distortions in 2008 results that might



have occurred if the tasks had been widely available for use in schools since 2004. In the current report, these tasks are called trend tasks and are used to examine trends in student performance: whether they have improved, stayed constant or declined over the four year period since the 2004 assessments.

Link Tasks

To allow comparisons between the 2008 and 2012 assessments, 14 of the tasks used for the first time in 2008 have been designated link tasks. Results of student performance on these tasks are presented in this report, but the tasks are described only in general terms because they will be used again in 2012.

Marking Methods

The students' responses were assessed using specially designed marking procedures. The criteria used had been developed in advance by Project staff, but were sometimes modified as a result of issues raised during the marking. Where tasks required marker judgement, the responses from year 4 and year 8 students were intermingled during marking sessions, with the goal of ensuring that the same marking criteria and standards were used for both. If these tasks were trend tasks, substantial representative samples of the responses of year 4 and year 8 students assessed in the earlier years were also intermingled into the marking process, to help ensure that all comparisons were based on the same marking criteria and standards.

Task-by-Task Reporting

National monitoring assessment is reported task by task so that results can be understood in relation to what the students were asked to do.

Access Tasks

Teachers and principals have expressed considerable interest in accessing NEMP task materials and marking instructions, so that they can use them within their own schools. Some are interested in comparing the performance of their own students to national results on some aspects of the curriculum, while others want to use tasks as models of good practice. Some would like to modify tasks to suit their own purposes, while others want to follow the original procedures as closely as possible. There is obvious merit in making available carefully developed tasks that are seen to be highly valid and useful for assessing student learning.

Some of the tasks in this report cannot be made available in this way. Link tasks must be saved for use in four years' time, and other tasks use copyright or expensive resources that cannot be duplicated by NEMP and provided economically to schools. There are also limitations on how precisely a school's administration and marking of tasks can mirror the ways that they are administered and marked by the Project. Nevertheless, a substantial number of tasks are suitable to duplicate for teachers and schools. In this report, these access tasks are identified with the symbol above, and can be purchased in a pack from the New Zealand Council for Educational Research (P.O. Box 3237, Wellington 6140, New Zealand), or email bev.webber@nzcer.org.nz. Teachers are also encouraged to use the NEMP website (<http://nemp.otago.ac.nz>).



Reading the Tasks and Results

ABOUT THE TASK

The content, instructions and key resources are shown for each task, as they were presented to the students. Sentences in bold blue are an instruction to the teacher administrator. The students' results are shown in red.

Students did this task by themselves in a station. See page 7 for descriptions of all four approaches used.

Trend Task: Bags

Approach: Station Year: 4 & 8

Focus: Evaluating decisions, strategies, outcomes and consequences

Resources: 4 pictures

What this task was aiming to evaluate.

The resources used in this task.

Questions / instructions:

Look at the **four** pictures of different types of school bags.

Think about what is good and not so good about each bag for carrying all your school things.



- In 2008, 6% of year 4 students gave a strong justification for their choice of bag.
- In 2004, 12% of year 4 students gave a strong justification for their choice of bag.
- In 2008, 17% of year 8 students gave a strong justification for their choice of bag.
- In 2004, 13% of year 8 students gave a strong justification for their choice of bag.

	% responses 2008 ('04)		% responses 2008 ('04)	
	year 4	year 8	year 4	year 8
1. Which bag would be the best to carry all your school things? Circle your bag choice.				
Chose bag:				
1	9 (11)	7 (5)	57 (57)	76 (61)
2	3 (6)	2 (2)	77 (78)	82 (87)
3	5 (1)	7 (6)	16 (21)	18 (23)
4	83 (81)	84 (987)	3 (4)	4 (2)
2. Write down the reasons why you chose that bag.				
carrying capacity	67 (73)	80 (76)		
easy/comfortable to carry/frees hands	52 (51)	65 (68)		
appearance/trendy	11 (18)	9 (17)		
apparent durability/strength of fabric	3 (2)	5 (4)		
Justification of choice:				
strong	6 (12)	17 (13)		
moderate	53 (49)	60 (56)		
weak	41 (40)	23 (31)		
3. For the other three bags write down the reasons why each one is not so good for carrying school things.				
carrying capacity			57 (57)	76 (61)
ease to wear/carry (and security)			77 (78)	82 (87)
appearance			16 (21)	18 (23)
apparent durability/strength of fabric			3 (4)	4 (2)
Total score:				
7-10	1 (5)	6 (7)		
6	5 (5)	15 (11)		
5	17 (22)	26 (26)		
3-4	54 (50)	42 (42)		
0-2	22 (19)	12 (14)		

The total score is created by adding those marking criteria that seem to capture best the overall task performance. For some tasks this is all of the criteria but for others, it is just one or two of the criteria.

Subgroup Analyses:

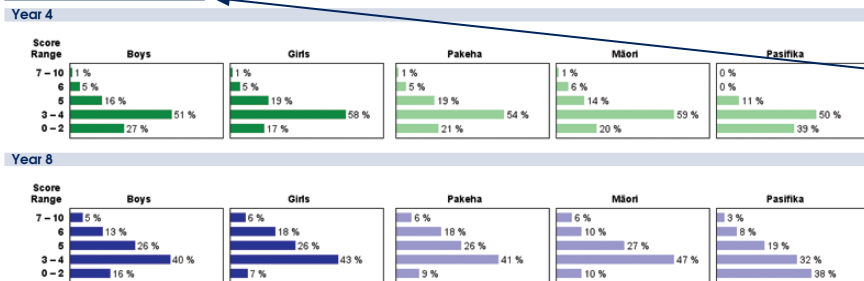

Performance patterns for boys and girls; Pakeha, Māori and Pasifika students, based on their total scores on the task. Note that Pakeha is defined as everyone not included in Māori or Pasifika.

Commentary:

Students greatly preferred the type of "backpack" bag that most of them use for school as their bag of preference. They were typically able to provide a reasonable justification for their choice, even at year 4. There were no gender differences in response. At year 4, Pakeha students received higher scores than Pasifika students, but there were no other differences by ethnicity. Scores were fairly similar to 2004.

Comments that assist with interpreting the results.

WHAT THE STUDENTS READ OR HEARD (BLUE) MARKING CRITERIA (RED)

PERFORMANCE PATTERNS

3 Technological Knowledge and Understanding

Overview: This chapter looks at student understanding of objects—their ability to describe and explain how objects work. Students' understanding of and knowledge about technology can best be described as moderate, with year 8 students being better able to describe and explain technological features of common objects than year 4 students. Change in performance from 2004 was negligible.



Details of the Tasks Administered

Nine of the technology tasks concerned technological knowledge and understanding. Seven of these tasks were identical for year 4 and year 8 students, and two of them were administered to year 8 students only. Five of the tasks were administered in 2004, thus allowing for looking at trends over time (we refer to these as “trend” tasks). Four of the tasks are what we call “link” tasks. Only basic information about these tasks is released in this report; these tasks will be administered again in 2012 for purposes of looking at growth.

The trend tasks are presented first, in detail, and then a summary of the link task information is presented.

Comparing Results for Year 4 and Year 8 Students

Substantial growth was seen from year 4 to year 8 on most, but not all, tasks. Generally speaking, year 8 students were able to provide more details when questioned about aspects of objects, and were able to provide better explanations of their ideas. There were 91 separate task components asked of students at both year 4 and year 8, with year 8 students providing correct or strong responses 41% of the time and year 4 doing so 32% of the time. This shows overall moderate growth in performance between year 4 and year 8.



Trend Results: Comparing 2004 Results with 2008

All five of the tasks presented in detail in this chapter include data from the 2004 administration of NEMP. At year 4, there were 52 task components administered with 2008 students providing correct or strong responses 29% of the time. The comparable figure for 2004 was 30%. Thus, there is a very slight decrease in performance from 2004 to 2008. At year 8, there were 73 task components that could be compared. Here the 2008 performance was 38% and the 2004 performance was also 38%. Thus the overall results at year 8 show no change.



Trend Task: Fishing Game

Approach: One to one
 Focus: Investigating, applying and evaluating design
 Resources: 2 fishing toy games (1 dismantled, 1 working order)

Year: 4 & 8

Questions / instructions:

In this activity you will be looking at a children's toy and telling me how it works.

Hand student toy game (working order).



This toy is a fishing game. The aim of the game is to catch as many fish as you can before it stops turning. I'll wind it up and you can play the game. See how many fish you can catch.

Wind up the toy and let the student play with it.

Now let's see how the toy works.

- How are the fish caught on the fishing line?

PROMPT: Can you show me how this works?

Explanation involving magnetic attraction:

mentioned magnet on fishing line, metal inside fish mouths	17 (21)	21 (30)
reverse of above, or identified both parts as magnets	44 (39)	57 (43)
general idea that a magnet is involved	30 (32)	21 (26)
no mention of magnet	8 (8)	1 (2)

Mentioned: fish are only "caught" when their mouths are open 32 (38) 31 (35)

- How do the fish open and close their mouths? You can use the toy to see how it works.

PROMPT: Can you show me how this works?

Explanation of turntable:

[(blue part) rotates/turns, sloping ramps (parts) underneath push fish up.]

clear explanation	7 (5)	20 (17)
vague explanation	29 (30)	37 (43)
mentioned ramps but not function	11 (15)	11 (13)
no mention of ramps	54 (50)	32 (27)

Mentioned: when fish are pushed up, their mouths fall open 39 (36) 55 (57)

% response
2008 ('04)
year 4 year 8

Hand student toy game (dismantled).



Here is the same toy but it has been taken apart so you can see how it works and how it is made.

Hand the student the winder mechanism.

- Look carefully at the winder. How does the winder make the game work?

Explanation of turning the winder to wind up a motor/spring:

specific mention of winding up spring (i.e. storing energy in spring)	4 (8)	13 (13)
vague idea of winding up motor	56 (61)	52 (55)
no relevant comment	41 (31)	35 (32)

Explanation of:

the spring/motor then making its axle (and/or the associated cogs) turn	23 (30)	37 (43)
the large cog alongside the spring making the other cog(s) and/or axle(s) turn	27 (29)	44 (38)
the cog on outside of motor connecting to cog on turntable (making it turn)	53 (49)	63 (67)

- Is there anything that could be done to make this a better toy for children?

PROMPT: What could be done?

Quality of ideas:	strong	12 (15)	20 (29)
	moderate	44 (36)	50 (41)
	weak	44 (49)	30 (31)

% response
2008 ('04)
year 4 year 8



5. Are there any people this toy might not be suitable for? Why?

dealt specifically with danger of removable small fish for little children who might put the fish in their mouths

Overall quality of ideas: strong 7 (12) 12 (17)
 moderate 60 (52) 56 (61)
 weak 33 (36) 32 (22)

		% response 2008 ('04)		% response 2008 ('04)	
		year 4	year 8	year 4	year 8
		54 (53)	68 (74)		
		7 (12)	12 (17)		
		60 (52)	56 (61)		
		33 (36)	32 (22)		
				Total score:	
				13-18	4 (9) 15 (14)
				10-12	16 (15) 28 (37)
				7-9	35 (23) 30 (28)
				4-6	30 (39) 22 (15)
				0-3	14 (13) 5 (6)

Subgroup Analyses:

Year 4

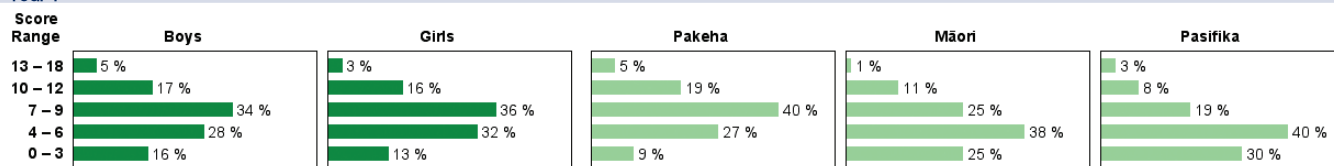

Year 8

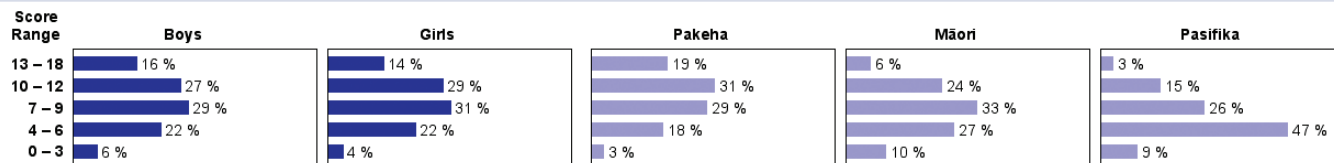

Commentary:

Students were moderately successful in explaining the workings of a mechanical game involving magnets, springs, cogs and a motor. Many students, at both years, had good ideas on how to improve the game. Gains from year 4 to year 8 were moderate. There were negligible gender differences. Pakeha students were more successful on the task than Māori and Pasifika students at year 8. Results were similar to the 2004 results.

Approach: One to one
 Focus: Investigating design
 Resources: Craft knife, cardboard, cutting block, diagram

Questions / instructions:

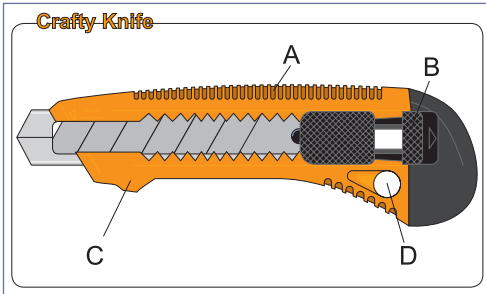

There are all sorts of craft knives. Have a good look at this one and try to notice all of its different parts.

You can hold it and move the blade in and out. Try to cut this card. But be careful.

Hand out craft knife, cardboard, cutting block. Ensure safe handling and use of the knife. Retract the blade at end.

Look at this diagram.

Hand out diagram. Point to A. Student can still hold craft knife.

1. Why is this part designed like this?

stops the slipping

53 (48) 88 (87)

Point to B.

2. Why is this part designed like this?

locks blade and moves blade
 locks blade or moves blade

9 (10) 22 (27)
 64 (57) 64 (59)

texture/shape help user

6 (8) 7 (6)

Point to C.

3. Why is this part designed like this?

helps to guide/control cutting action/
 place to rest finger

37 (34) 56 (50)

Point to D.

4. Why is this part designed like this?

for hanging knife up

54 (58) 73 (67)

5. If you were going to use this craft knife, what safety rules would you have to follow?

keep blade length as short as needed
 store with blade retracted
 keep fingers out of way
 don't walk around with blade out
 (near other people)
 don't press too hard

7 (5) 14 (12)
 12 (19) 38 (26)
 56 (58) 50 (51)
 11 (13) 18 (20)
 2 (1) 2 (2)

6. Why might someone use a craft knife instead of a pair of scissors?

cut inside shapes (like circle)
 sharper than most scissors/suitable
 for harder to cut materials
 stays sharp/easier to keep sharp

7 (7) 29 (29)
 57 (62) 52 (46)
 4 (4) 6 (3)

Total score: 8-13 0 (0) 11 (9)
 6-7 10 (14) 39 (37)
 4-5 41 (43) 36 (34)
 2-3 40 (36) 13 (17)
 0-1 9 (7) 2 (3)

Subgroup Analyses:

Year 4

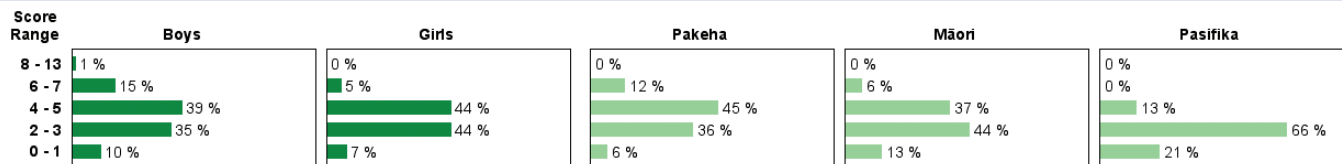

Year 8

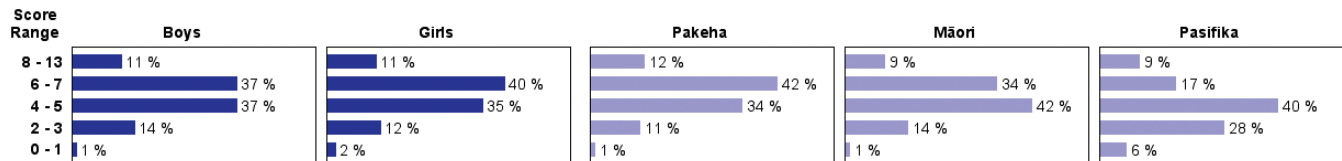

Commentary:

Although students at year 4 had some difficulty explaining the design elements of a craft knife, by year 8 students showed a fairly strong grasp of the concepts. There were negligible gender differences. Differences among Pakeha, Pasifika and Māori students were fairly strong at year 4, but diminished for the year 8 students. Results were similar to performance in 2004.

Approach: Station

Year: 4 & 8

Focus: Evaluating decisions, strategies, outcomes and consequences

Resources: Series of stills on laptop computer; *Cookie Time* biscuit

Questions / instructions:

This activity uses the computer. Click on the button that says *Cookie Time*.

[Series of stills; audio track matches on-screen text]



First I dream up an idea...



Then I trial and taste recipes until one is chosen.



I buy the raw ingredients...



Then the ingredients are mixed up to make cookie dough!



The cookie dough is then pressed into cookie shapes...



Then racks of cookies are put into the ovens for baking.



Once baked, I use a wrapping machine to put the wrappers on.



Boxes of cookies are prepared to send around New Zealand.



Cookies are delivered to shops everywhere



For serious cookie munchers to MUNCH!!!

- Why do you think they trial and test new recipes?
 - make sure people like the taste of them (so they will buy them/get the best one)
 - make sure recipe works well to avoid negative effects to the company/business (i.e., check works well so don't lose money/avoid bad results, harm, loss of reputation to the company)
- How do you think they would trial and test new recipes?
 - survey (ask) people about the cookie they might like
 - Make up new recipes:
 - same recipe several times
 - once
 - get possible customers to trial/taste/ eat new biscuit recipes
 - get customer's opinions (have people taste new biscuits and give feedback)

% response 2008 ('04)	
year 4	year 8
55 (60)	73 (69)
9 (7)	14 (15)
4 (7)	4 (6)
1 (1)	9 (4)
4 (4)	10 (7)
18 (10)	15 (15)
43 (45)	62 (68)
4 (8)	12 (9)

- Try to give three reasons why the biscuits are wrapped.

% response 2008 ('04)	
year 4	year 8
fresh	47 (40) 68 (67)
health/hygiene reasons (prevent people touching or eating them)	62 (74) 74 (75)
marketing/advertising of brand/use of bar codes	10 (15) 28 (17)
nutrition/ingredients information	5 (7) 13 (5)
Total score:	5-10 6 (9) 29 (18)
	3-4 46 (43) 54 (65)
	2 30 (34) 11 (14)
	1 14 (11) 4 (3)
	0 4 (3) 2 (1)

Subgroup Analyses:

Year 4

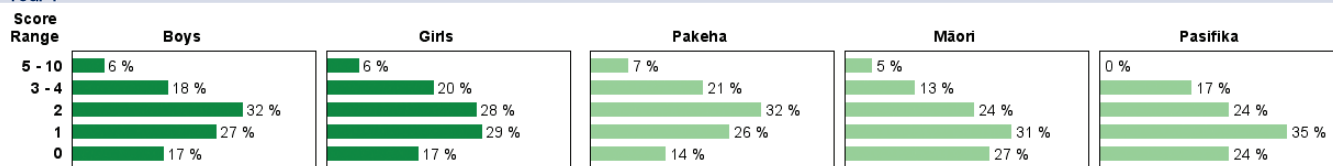

Year 8

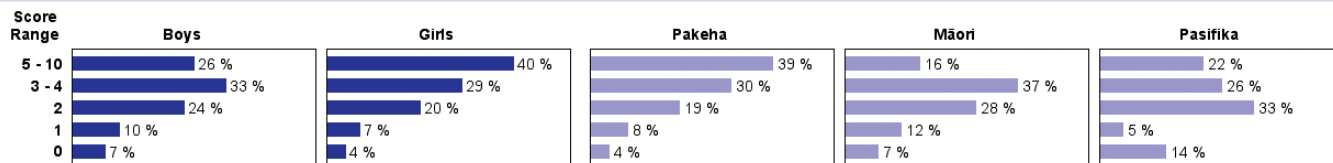

Commentary:

Most students were able to provide good reasons for why a cookie factory develops and tests new ideas for cookies, and why they wrap their product. There was moderate growth seen from year 4 to year 8. There were minimal gender differences at year 4, but girls outperformed boys at year 8. Pakeha students outperformed Māori and Pasifika students at year 4 and year 8. Moderate growth was seen from 2004 to 2008 at year 8.

Trend Task: Bags



Year: 4 & 8

Approach: Station
 Focus: Evaluating decisions, strategies, outcomes and consequences
 Resources: 4 pictures

Questions / instructions:

Look at the **four** pictures of different types of school bags.

Think about what is good and not so good about each bag for carrying all your school things.



1. Which bag would be the **best** to carry all your school things? Circle your bag choice.

Bag:	1	2	3	4
Year 4	9 (11)	3 (6)	5 (1)	83 (81)
Year 8	7 (5)	2 (2)	7 (6)	84 (87)

2. Write down the reasons why you chose that bag.

Reason	Year 4	Year 8
carrying capacity	67 (73)	80 (76)
easy/comfortable to carry/frees hands	52 (51)	65 (68)
appearance/trendy	11 (18)	9 (17)
apparent durability/strength of fabric	3 (2)	5 (4)
Justification of choice:		
strong	6 (12)	17 (13)
moderate	53 (48)	60 (56)
weak	41 (40)	23 (31)

3. For the other three bags write down the reasons why each one is **not so good** for carrying school things.

Reason	Year 4	Year 8
carrying capacity	57 (57)	76 (61)
ease to wear/carry (and security)	77 (78)	82 (87)
appearance	16 (21)	18 (23)
apparent durability/strength of fabric	3 (4)	4 (2)
Total score:		
7-10	1 (5)	6 (7)
6	5 (5)	15 (11)
5	17 (22)	26 (26)
3-4	54 (50)	42 (42)
0-2	22 (19)	12 (14)

Subgroup Analyses:

Year 4

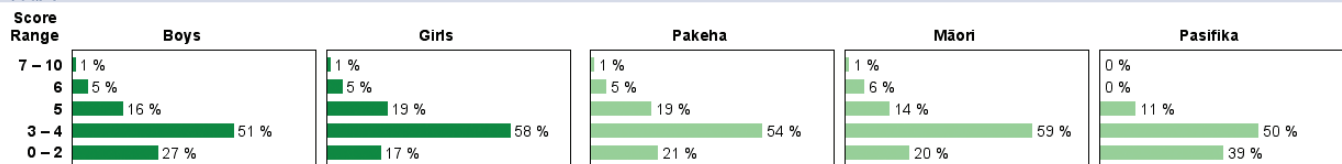

Year 8

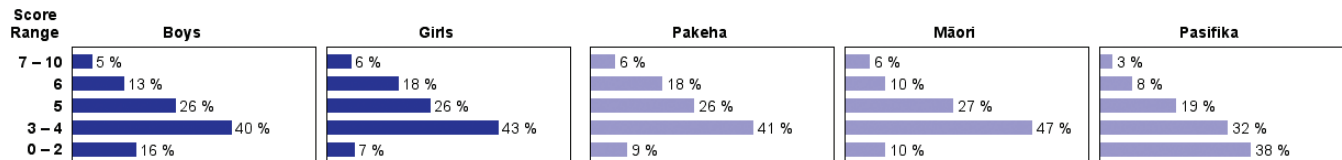

Commentary:

Students greatly preferred the type of “backpack” bag that most of them use for school. They were typically able to provide a reasonable justification for their choice, even at year 4. There were negligible gender differences in response. At both year levels, scores were fairly similar to the 2004 scores.

Approach: Station

Year: 8

Focus: Evaluating decisions, strategies, outcomes and consequences

Resources: Work book

Questions / instructions:

When people go tramping or hiking they often stay away from home for a few nights. They stay in huts or tents and have to pack food to carry with them.

- Put a tick ✓ to show if the food would or would not be good to take tramping.

Food	Good to take on a tramp	Not good to take on a tramp
Yoghurt		✓
Cream Cake		✓
Muesli Bars	✓	
Kumara		✓
Oranges	✓	
Dried Noodles	✓	
Bottle of Coke		✓
Dried vegetables	✓	
Milk powder	✓	

% response
2008 ('04)

year 8

54 (56)
92 (94)
97 (98)
51 (49)
94 (92)
62 (69)
69 (65)
80 (75)
69 (78)

% response
2008 ('04)

year 8

- What are some important things to think about when choosing food to take on a tramp? Try to give **three or more** things to think about.

amount needed 7 (8)
weight 18 (16)
capacity/space 15 (12)
likelihood of damage 16 (23)
likelihood of decay 40 (43)
nutritional value 30 (31)
easy to prepare 24 (25)
nice to eat 5 (1)
disposal of packaging 2 (0)
energy 34 (25)
Water: water hydration 4 (7)
water 19 (16)

Total score: 15-21 10 (9)
10-14 30 (29)
8-9 34 (38)
6-7 21 (20)
0-5 5 (5)

Subgroup Analyses:

Year 8

Score Range

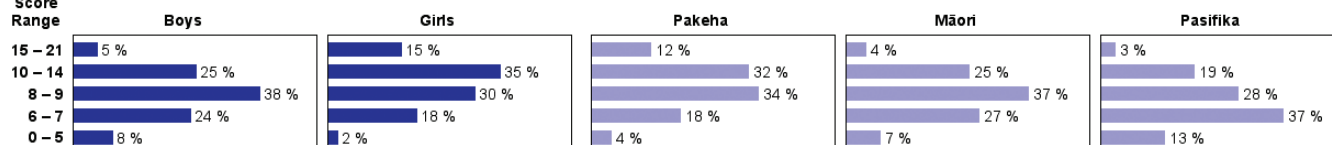

Commentary:

Student choices for what food to take on a multi-day tramp ranged from the highly practical (muesli bars) to the highly desirable (cream cakes). In general, students made good choices on what to include. Girls made better choices than boys and were better able to give reasons for their choices. Pakeha students scored higher than Māori or Pasifika students; there were negligible changes from the 2004 administration.

Link Tasks 1 – 4

% responses
y4 y8

LINK TASK: 1

Approach: One to one

Year: 4 & 8

Focus: Investigating and evaluating design

Total score:	9-13	3	12
	7-8	10	24
	5-6	28	33
	3-4	39	22
	0-2	21	9

LINK TASK: 2

Approach: One to one

Year: 4 & 8

Focus: Investigating and evaluating design

Total score:	8-10	0	7
	6-7	5	22
	4-5	30	41
	2-3	46	24
	0-1	20	5

LINK TASK: 3

Approach: One to one

Year: 4 & 8

Focus: Explaining how a tool works

Total score:	11-17	2	14
	9-10	10	21
	7-8	28	35
	5-6	35	23
	0-4	26	7

LINK TASK: 4

Approach: One to one

Year: 8

Focus: Investigating and evaluating design;
use of technology

Total score:	7-8		33
	6		26
	5		19
	4		10
	1-3		12

4 Technological Capability

Overview: The area of technological capability primarily involves issues of generating and evaluating designs for objects. In this chapter, students looked at lemon squeezers, school desks, and eel traps among other objects. Year 8 students show substantial growth over the year 4 students in this area, particularly in the ability to generate designs for objects. The two age groups are somewhat closer when it comes to evaluating existing designs. There is a slight decrease in performance from 2004 found for both groups.



Details of the Tasks Administered

The 2008 Technology assessment included 11 tasks in the area of technological capability. Eight of the tasks were identical for years 4 and 8, and three of the tasks were administered to year 8 students only. Four of the tasks are what we call “trend” tasks. These tasks have been administered in 2004, and comparisons over time can be made with these tasks. Six of the tasks are what we call “link” tasks. We report only basic information in this report, and will re-administer the tasks in 2012 in order to look at trends at that time. One task was developed for the 2008 administration for which full information will be presented in this report.

Comparing Results for Year 4 and Year 8 Students

Students show substantial growth from year 4 to year 8 in terms of technological capability. This is particularly true when students have to generate a design, more so than when they are asked to evaluate an existing design. This can be seen in the *Exercising Rats* task (p23), *Shell Container* (p27) and in two of the link tasks for which results can be seen on page 31. There were a total of 90 task components administered to year 4 and year 8 students. On average, year 4 students provided correct or strong responses 36% of the time, whereas year 8 students were successful 48% of the time. It is in the area of generating ideas that we see the greatest gains.

Trend Results: Comparing 2004 Results with 2008

The results show a small decline in performance at both year 4 and year 8. There were 35 tasks administered to both 2004 and 2008 samples at year 4, with 2008 students providing strong or correct responses 27% of the time. The corresponding figure for 2004 is 31%. At year 8, there are 42 task components in common; 2008 students were successful 38% of the time compared to 40% for the 2004 students. At both years, the decrease from 2008 to 2004 is fairly small.



Approach: One to one
 Focus: Evaluating design
 Resources: Video on laptop computer (no sound), 4 pictures

Questions / instructions:

This activity uses the computer.

We are going to watch a video of someone using four different types of lemon squeezers. As you watch, think about the things that make a lemon squeezer work well.

Click the **A Bit of a Lemon** button. No sound with this video.

[Silent video, demonstrating each of the lemon squeezers as adjacent.]

Hand out four pictures.

Here are pictures showing juice from the four different lemon squeezers.

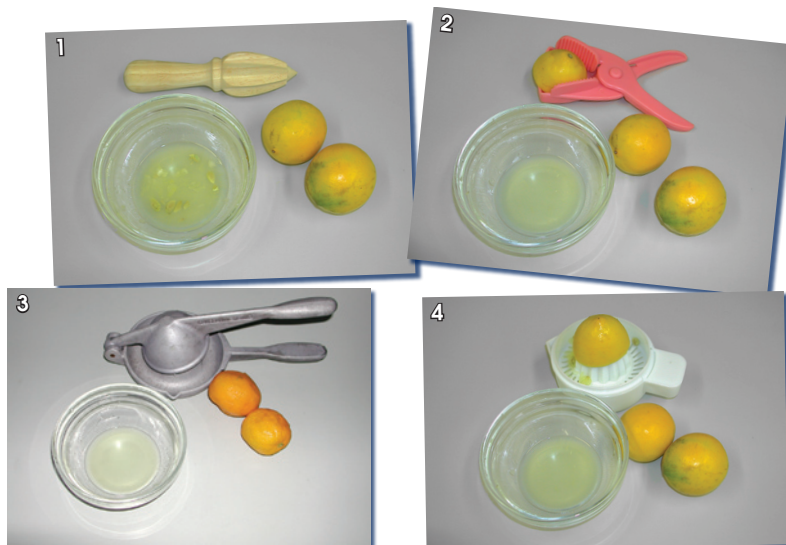

		% response 2008 ('04)			% response 2008 ('04)	
		year 4	year 8		year 4	year 8
1. Which lemon squeezer do you think worked best?	4	25 (24)	29 (25)			
	3	52 (58)	53 (60)			
	2	5 (7)	4 (4)			
	1	17 (12)	14 (10)			
2. What were the things that made it the best lemon squeezer?				Total score:	4	0 (0)
	gets lots of juice	41 (34)	46 (38)		3	4 (9)
	stops pips getting into juice	37 (41)	59 (63)		2	31 (33)
	easy to use and/or not tiring	39 (58)	56 (62)		1	50 (46)
	not too messy to use	7 (6)	9 (13)		0	15 (12)
						6 (5)

Subgroup Analyses:

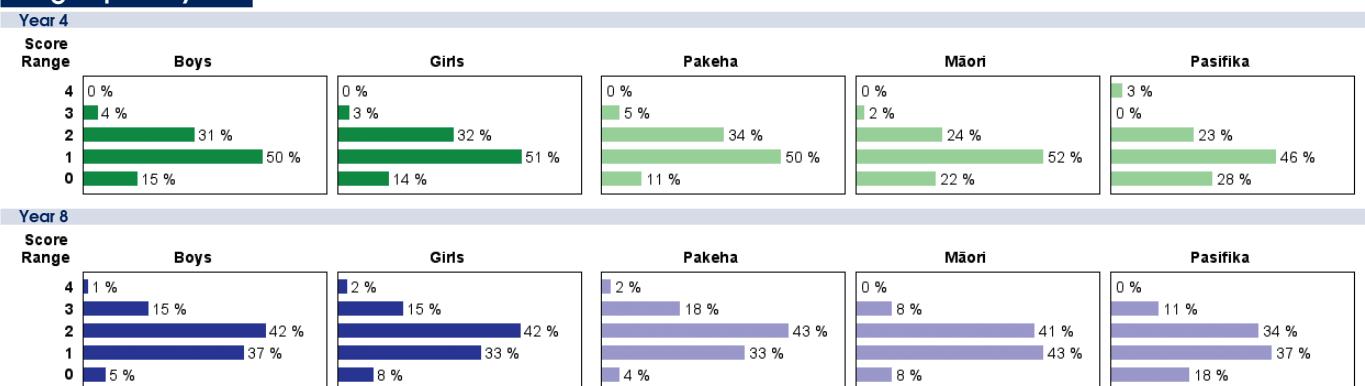

Commentary:

About one third of year 4 students and three fifths of year 8 students were able to provide at least two sound reasons behind their choice of a lemon squeezer. Differences between year 4 and year 8 were not particularly large. There were minimal gender differences. Performance was similar in 2004 and 2008.

Approach: Station

Year: 4 & 8

Focus: Generating design

Resources: Video on laptop computer (no sound); work book



Questions / instructions:

This activity uses the computer.

All pets need exercise to keep them healthy. On the computer you'll see a boy trying to get his rat to exercise. Click on the button that says **Exercising Rats**. (There is no sound).

The rat is very fat because it does not get enough exercise. It is bored with its wheel and won't use it. The boy has to go to school so the rat can't crawl on him all the time.

1. Design **two** pieces of equipment for the rat, to help it exercise.
2. Show what the rat would do with each piece of equipment.

Remember:

- a) Rats can climb, jump, run and burrow.
- b) The equipment must fit in the cage.
- c) The new equipment needs to be more interesting than the wheel.

First piece of equipment:

		% response 2008 ('04)	
		year 4	year 8
Met the criteria:	quite well <i>(had exercise potential, did fit cage and appeared interesting)</i>	15 (16)	31 (26)
	somewhat <i>(had some exercise potential and did fit cage)</i>	49 (58)	53 (58)
	did not meet the criteria <i>(did not fit cage or provided wheel already given)</i>	36 (26)	16 (16)
Clarity of use of equipment:	equipment identified <u>and</u> explained	13 (25)	38 (35)
	equipment identified <u>or</u> explained	41 (46)	38 (49)
Clarity of the construction and mechanisms involved:	high	9 (10)	29 (25)
	moderate	34 (37)	42 (43)
	low	57 (53)	29 (32)

Second piece of equipment:

		% response 2008 ('04)	
		year 4	year 8
Met the criteria:	quite well <i>(had exercise potential, did fit cage and appeared interesting)</i>	10 (8)	27 (17)
	somewhat <i>(had some exercise potential and did fit cage)</i>	51 (57)	48 (58)
	did not meet the criteria <i>(did not fit cage or provided wheel already given)</i>	40 (35)	26 (25)
Clarity of use of equipment:	equipment identified <u>and</u> explained	10 (19)	30 (25)
	equipment identified <u>or</u> explained	35 (42)	38 (47)
Clarity of the construction and mechanisms involved:	high	3 (7)	20 (15)
	moderate	32 (30)	39 (38)
	low	65 (63)	42 (47)
Total score:	9-13	5 (9)	27 (21)
	7-8	10 (13)	16 (18)
	5-6	19 (24)	21 (23)
	3-4	24 (20)	16 (24)
	0-2	43 (35)	20 (14)

Subgroup Analyses:

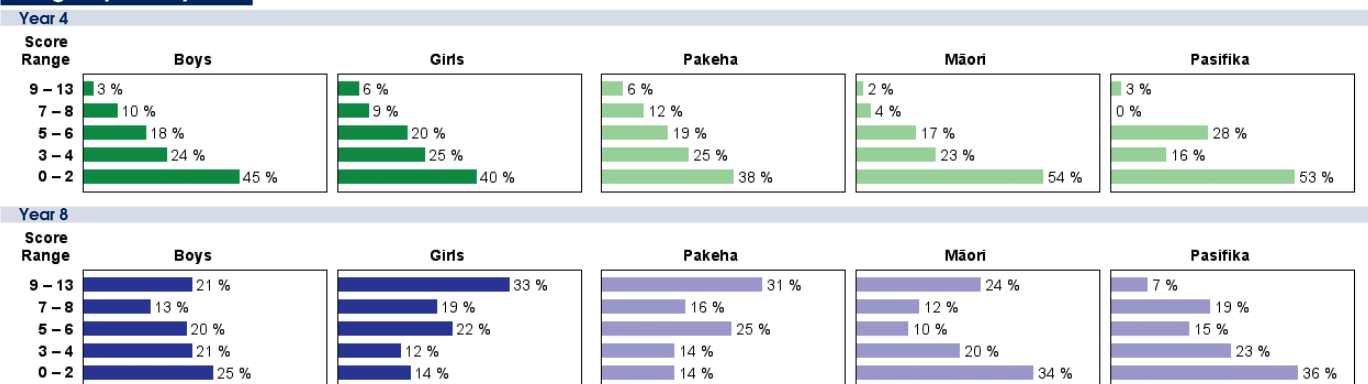

Commentary:

Year 4 students struggled in trying to design two different pieces of equipment for exercising rats. Year 8 students showed substantially higher performance than year 4 students. Girls at year 8 performed better than boys, and Pakeha students performed better than Māori and Pasifika students. Performance at year 4 seems to have declined slightly, with little change at year 8 between 2004 and 2008. *[Exemplars overleaf.]*

YEAR 4 : MID RANGE :

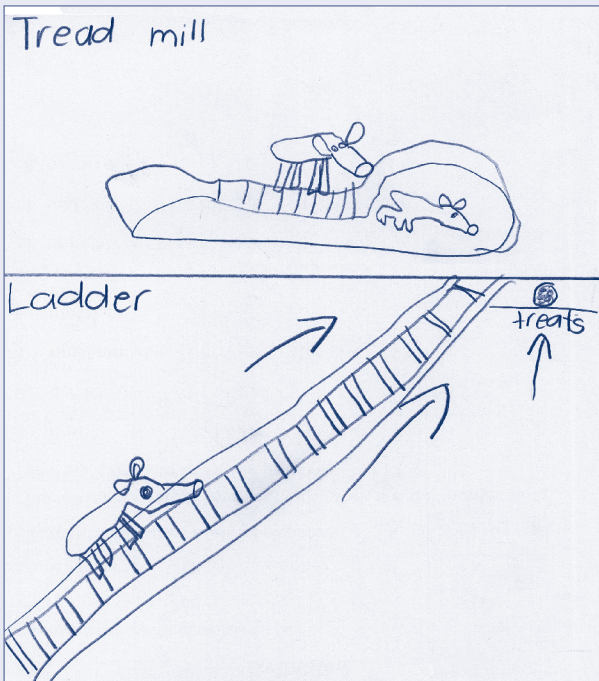
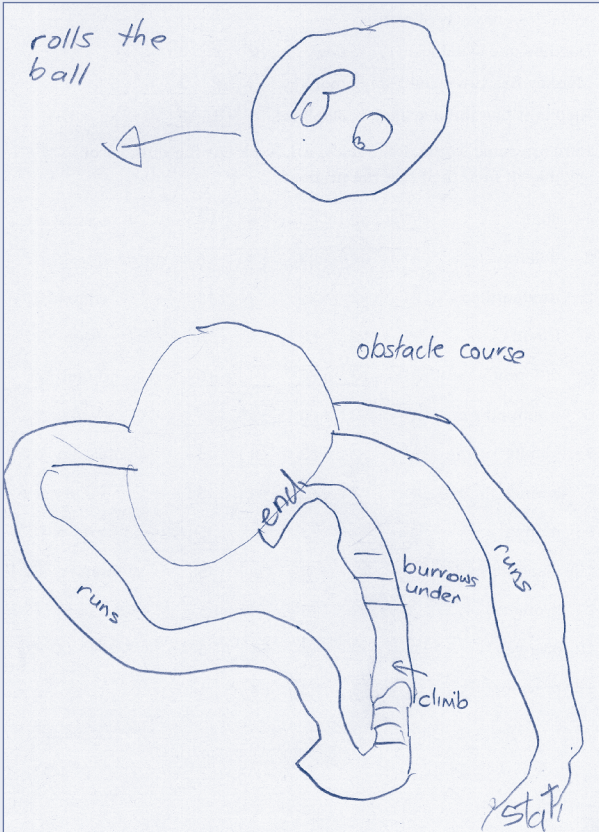

YEAR 4 : HIGH RANGE :

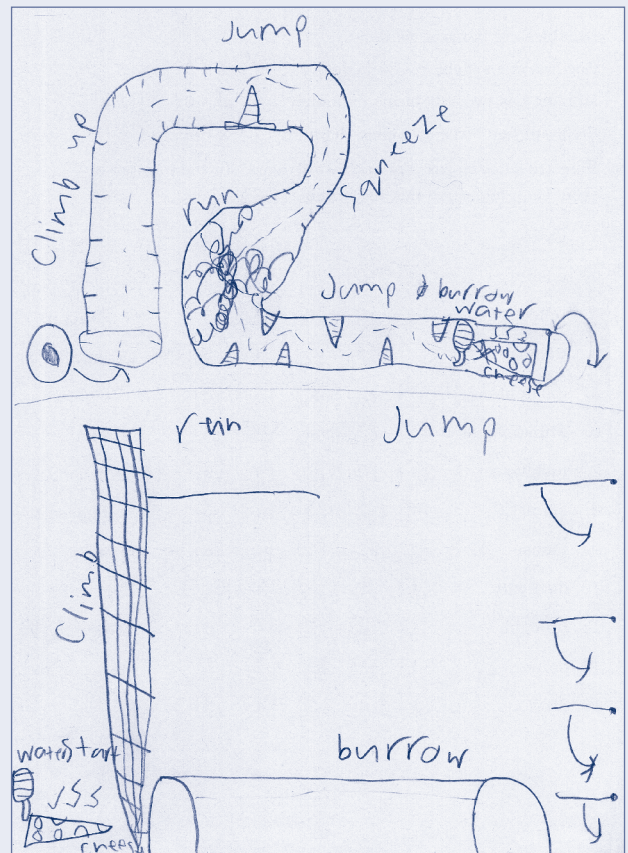
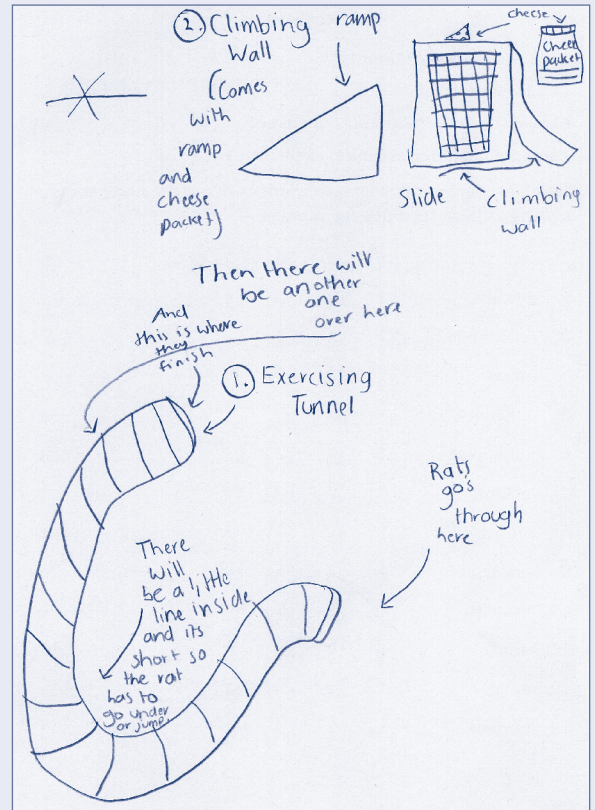

YEAR 8 : MID RANGE :

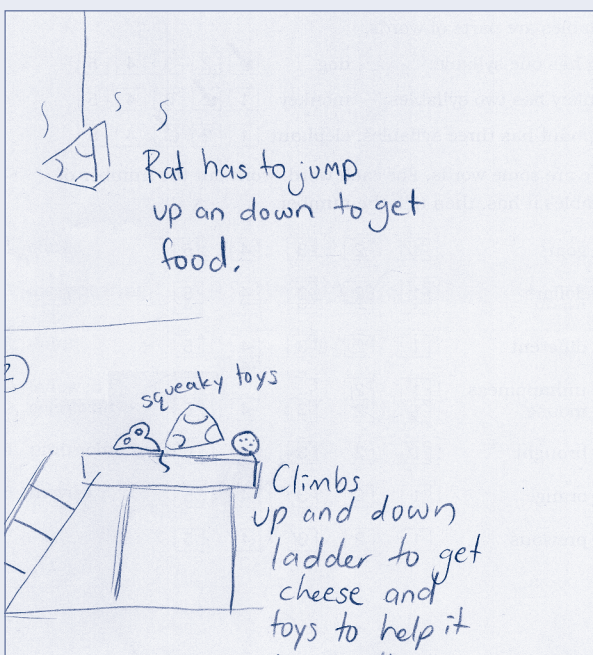
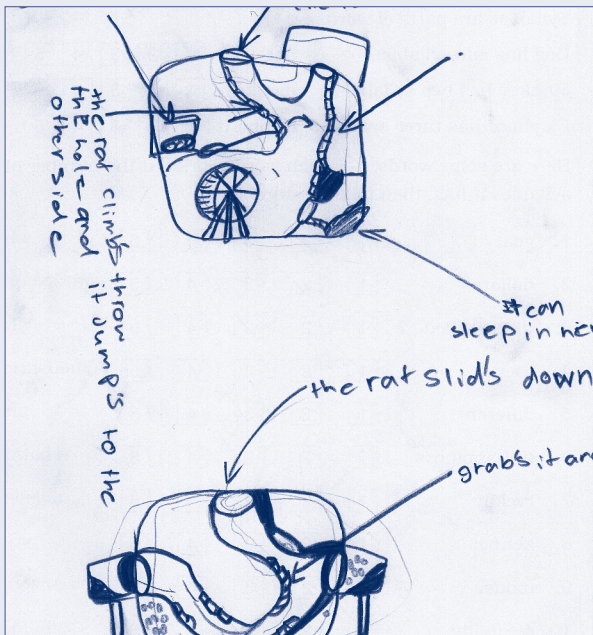
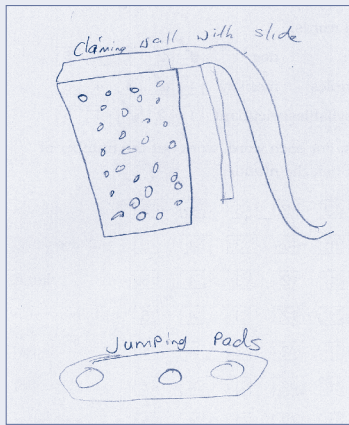

YEAR 8 : HIGH RANGE :

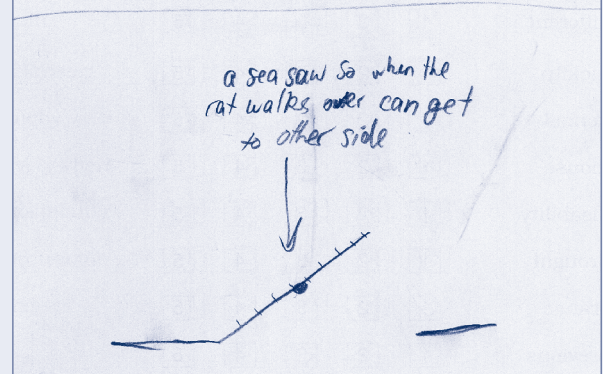
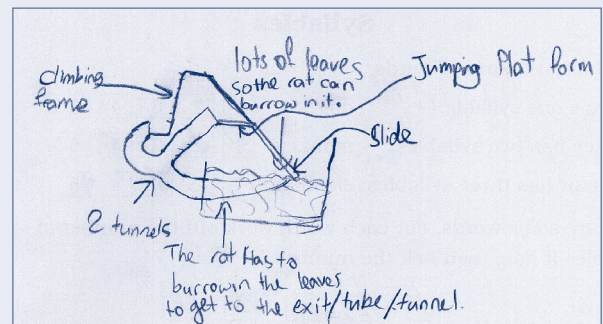
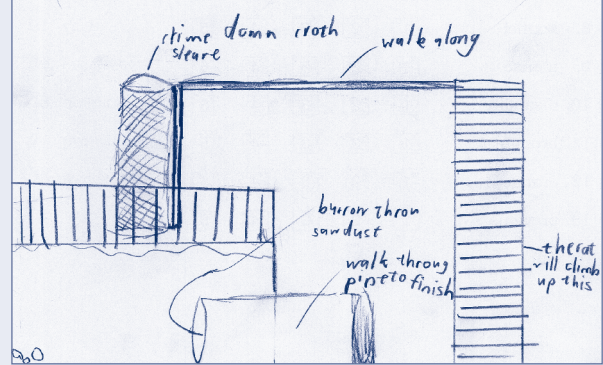
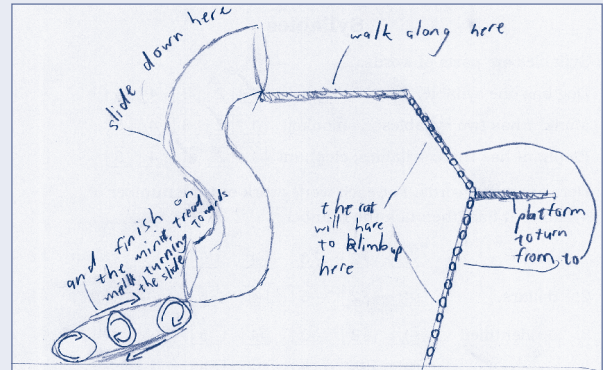

Approach: Station
 Focus: Investigating and evaluating design
 Resources: Picture

Questions / instructions:

Look at the picture of the eel.

Eels are a type of fish but they look a bit like a snake. They are slippery. They eat fish, bugs or meat.

Eels live in rivers and streams.

1. Draw arrows to parts of the eel trap that make it a good eel trap.
2. Beside each of your arrows write how that part of the trap makes it a good eel trap.

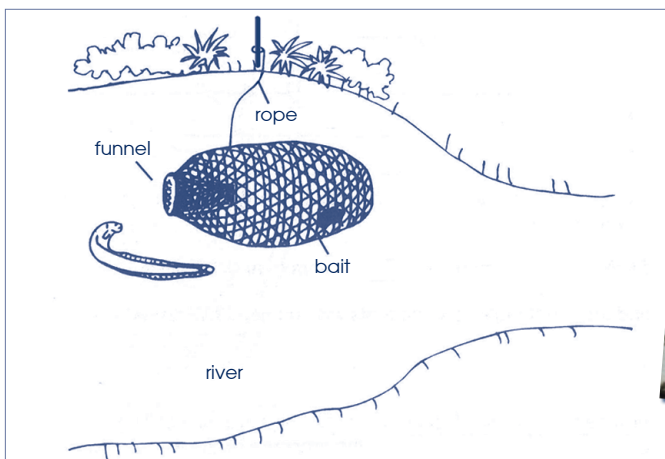

	% response 2008 ('04)		% response 2008 ('04)
Rope: (to hold trap in place)	year 8	Bait: (to entice eel into trap)	year 8
identified and explained	49 (61)	identified and explained	74 (70)
not identified, but explained	2 (2)	not identified, but explained	3 (1)
identified (arrow drawn)	20 (16)	identified (arrow drawn)	8 (10)
Funnel: (to let eel in but not out)		Netting: (see or smell bait/keep eels inside/ allow water to flow through)	
identified and mentioned trapping effect	31 (27)	identified and explained	22 (22)
not identified, but mentioned trapping effect	1 (2)	not identified, but explained	0 (0)
identified and mentioned lets eels in	38 (44)	identified (arrow drawn)	5 (10)
not identified, but mentioned lets eels in	4 (6)	Total score:	
identified only, no adequate explanation	10 (10)	8-9	10 (10)
		6-7	40 (49)
		4-5	32 (27)
		2-3	16 (12)
		0-1	3 (2)

Subgroup Analyses:

Year 8

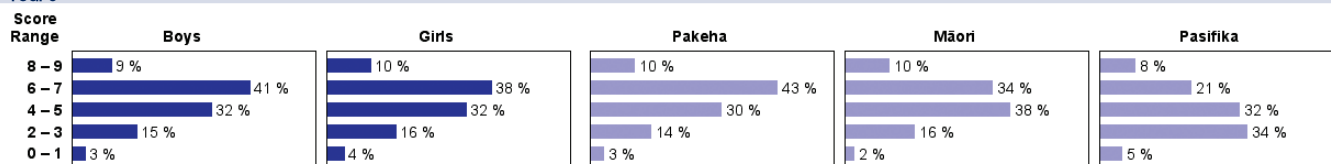

Commentary:

Most students had a basic understanding of how the eel trap worked and could explain some of the essential features of the trap. There were minimal gender differences in performance, nor much change from 2004 to 2008.

Approach: Independent

Year: 4 & 8

Focus: Generating and evaluating design

Resources: 4 shells (same type and size), 4 rulers, 4 answer sheets

Questions / instructions:

Show students a shell.

In this activity you are going to design a container for one of these shells. The container should be a good size for the shell, and it should be able to be opened and closed. Start by making two quick drawings or sketches of your ideas. Then choose one of your ideas for making a detailed plan for your container. Draw your plan so that if someone else used the plan, they would know exactly how the container is to be made. You will be working on your own. Try to do your very best without getting help from the others in the group, and follow the instructions on your answer sheet.

Give each student an answer sheet, ruler and shell. Ensure students work independently.

Student work sheet:

1. Make **two quick drawings** of your ideas for the container.
2. Draw a detailed plan for **one** of your ideas.
3. The container should be a good size for the shell. It should be able to be opened and closed.
4. The plan needs enough information to show someone exactly how it is to be made.

Which idea do you like best? Circle your answer: First Second

Now draw a plan for your best idea. Your plan needs to be clear so that someone else would know how to make the shell container.

Your plan should show:

- The size and measurements of the container.
- What the container is made of.
- How the container is held together.
- How it opens and closes.

Put labels on your plan.



	% response 2008 ('04)			% response 2008 ('04)	
	year 4	year 8		year 4	year 8
Concept: included one or more conceptual drawings in addition to final plan	99 (99)	100 (99)	Provided information on:		
			material(s) for container	64 (86)	78 (82)
Plan included:			how container is held together	42 (57)	57 (71)
3D drawing and net	0 (1)	5 (11)	Clear where container opens and closes:		
3D drawing	48 (44)	69 (59)	yes, with details	8 (13)	28 (33)
net	5 (6)	8 (20)	yes, but without details	51 (51)	52 (53)
Shape of the container:			plan included a transparent "window" so the shell can be seen when the box is closed (optional)	7 (8)	11 (6)
special shape linked to shell shape	21 (26)	33 (42)	Overall judgement of clarity and detail of plan for another person to make container:		
rectangular prism/shape	61 (57)	62 (53)	very good	0 (0)	5 (7)
Is it possible to make a container from the plan? (ignoring dimensions at this point)			quite good	2 (1)	22 (29)
yes, appropriate overlapping joins/tabs/seam allowance	1 (3)	9 (21)	key details missing or unclear	29 (51)	52 (45)
yes, but with butt joins	28 (33)	61 (52)	seriously inadequate	69 (49)	21 (19)
Measurements included: (including units)			Total score:		
sufficient to make container to size	3 (7)	31 (40)	10-12	2 (4)	26 (38)
some, but not sufficient	48 (63)	51 (42)	8-9	8 (16)	22 (24)
Measurements appropriate to size of shell (base 7.5cm, height 7cm, sloping sizes about 9cm; can allow up to 2.5cm more for packing space.)			6-7	19 (28)	27 (19)
all	2 (2)	16 (22)	4-5	29 (29)	16 (13)
some	21 (33)	43 (44)	0-3	43 (24)	8 (7)
none	76 (65)	41 (34)			

Subgroup Analyses:

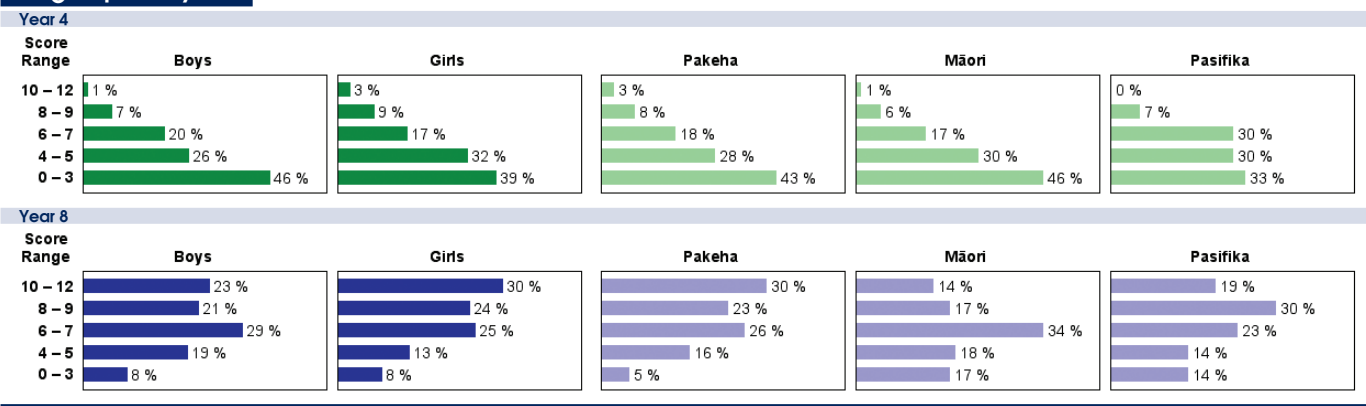

Commentary:

Strong growth from year 4 to year 8 was seen in this task involving generating and evaluating a design for a container. Year 4 students had particular difficulty in coming up with a thorough plan with good measurements of the dimensions. Pakeha, Māori and Pasifika students performed similarly at year 4; at year 8, Pakeha students performed better than Māori students. [Exemplars overleaf.]

Shell Container : Exemplars

YEAR 4 : MID RANGE :

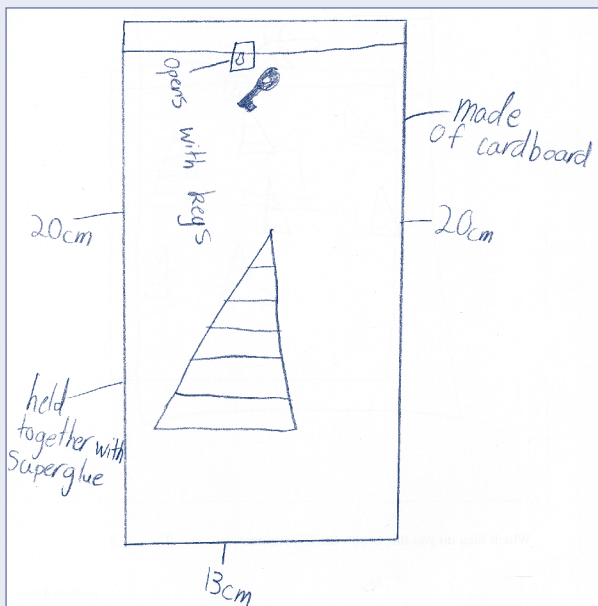
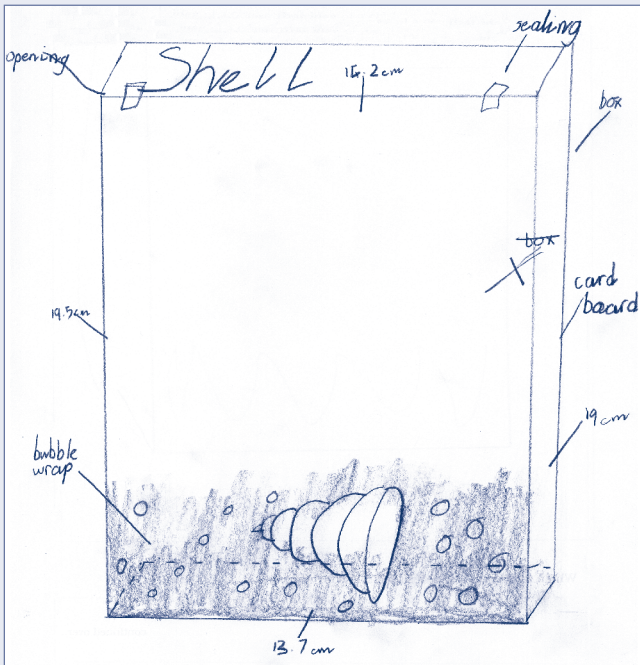
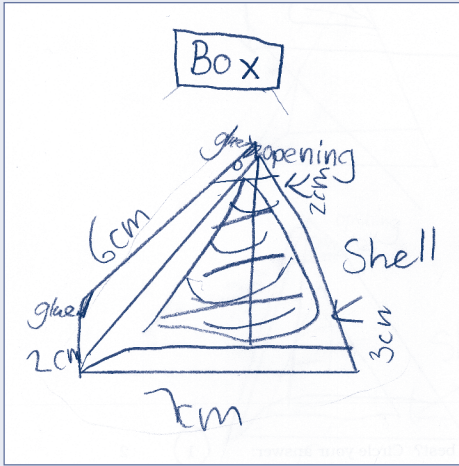

YEAR 4 : HIGH RANGE :

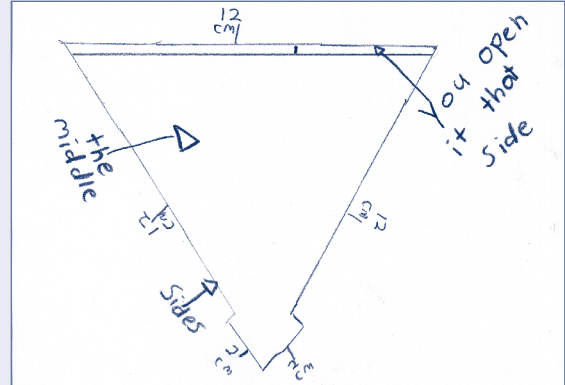

a plastic container.
by sticky tape

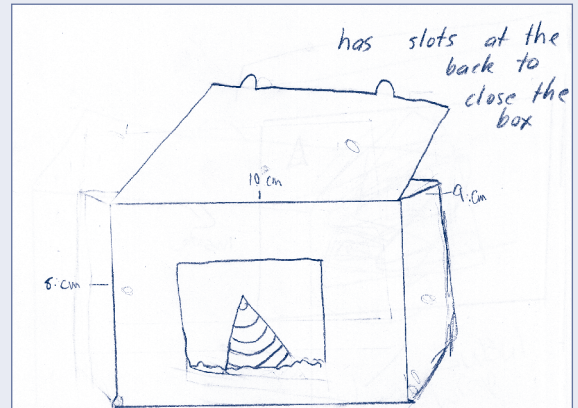

made of Card Board
recycle an old box
held together with sellotape

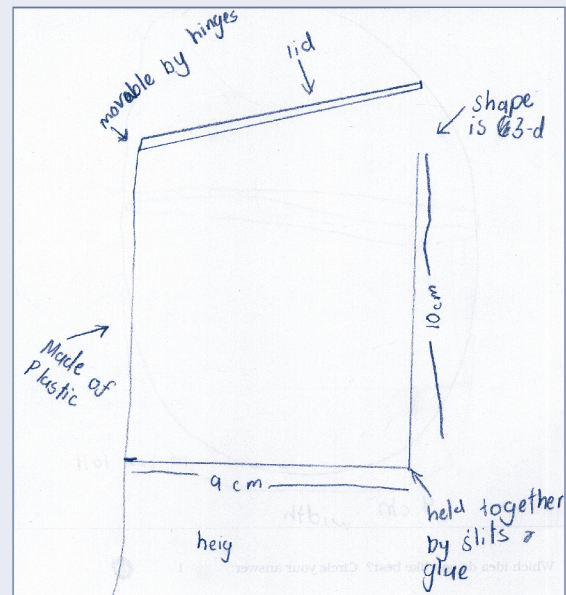

YEAR 8 : MID RANGE :

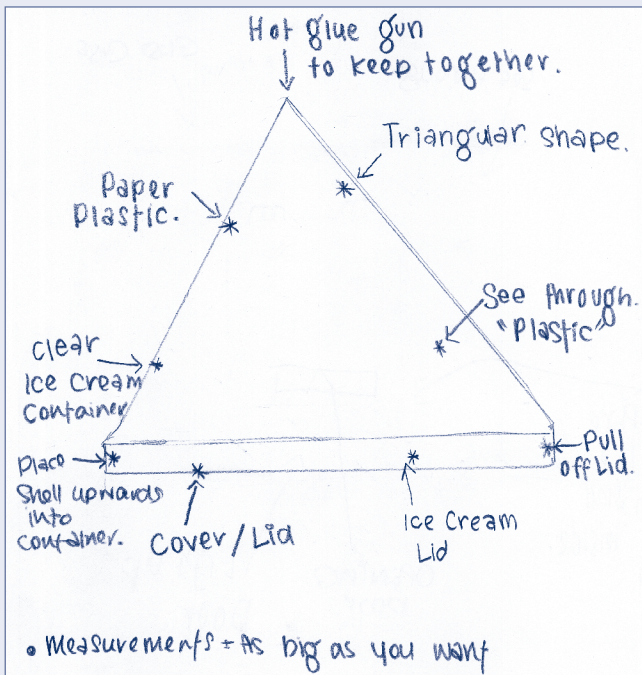
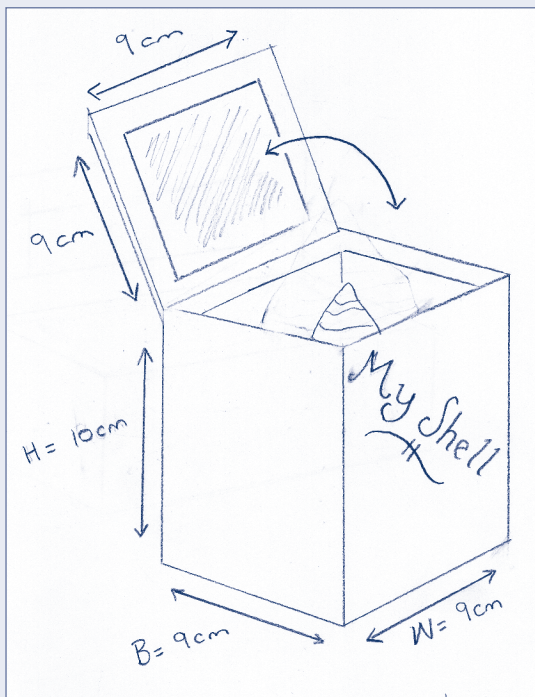
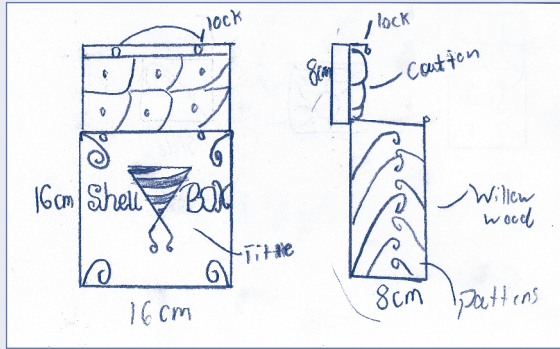

YEAR 8 : HIGH RANGE :

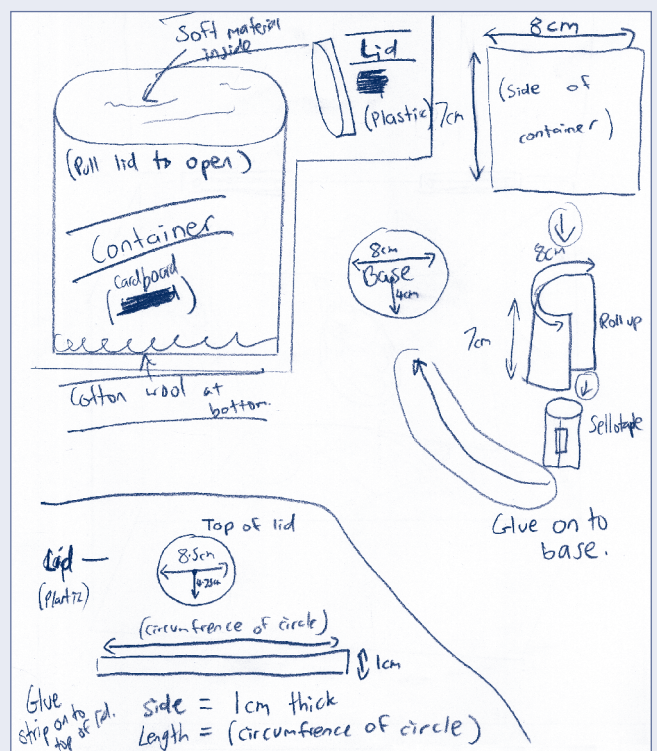
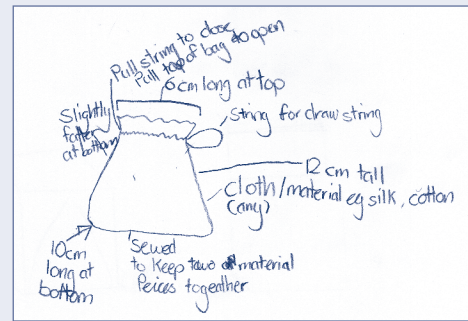
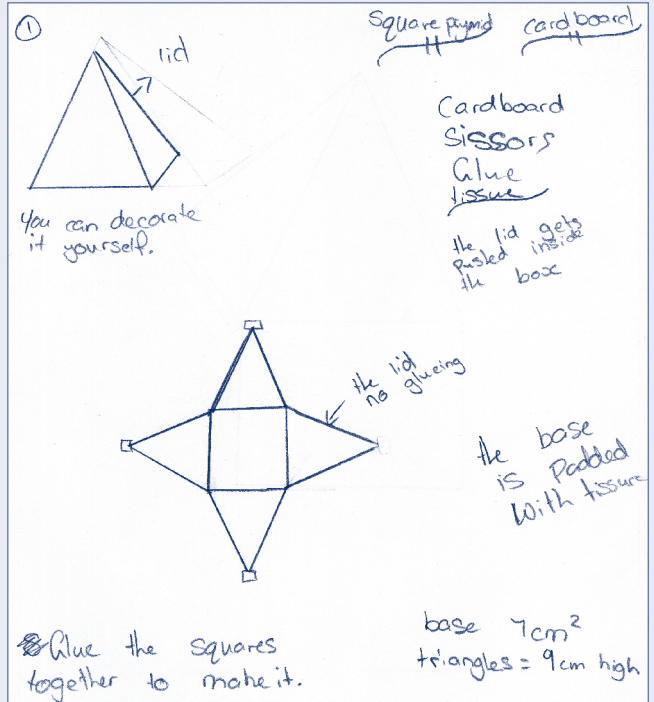

Approach: Station
 Focus: Product analysis/evaluating decisions
 Resources: 4 furniture pictures

Questions / instructions:

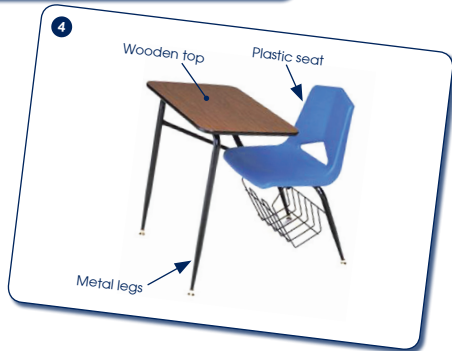
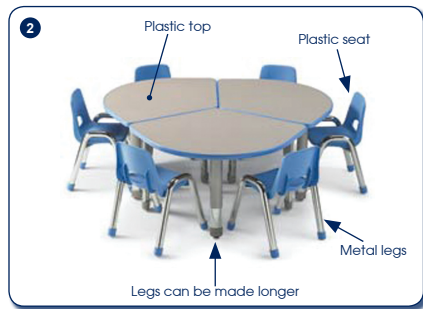
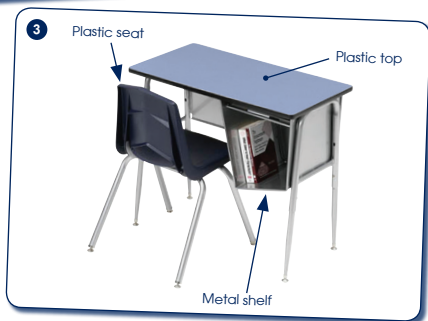

Some children are allowed to choose new furniture for their classroom.

1. What are some **good** things about the **designs** of the furniture?
2. What are some **good** things about the **materials** the furniture has been made from?
3. What are some **not so good** things about the **designs** of the furniture?
4. What are some **not so good** things about the **materials** the furniture is made from?

Designs:

Good and not so good things: storage
 convenience/capacity/flexibility of storage
 encouraging working together vs individually
 chair attached to desk vs independent chair
 adjustability of desk legs
 arrangements for moving/picking up chairs

Materials:

Good and not so good things : strength
 (not likely to fail on a single occasion)
 easy to keep clean
 appropriate ends of legs (noise, damage to flooring)
 durable materials (keep on working well, looking good)

5. Circle the number of the furniture you would choose?
 - 1
 - 2
 - 3
 - 4
 - no choice made

6. Explain why you would choose that furniture.
 - strong
 - moderate
 - weak

Total score: 9-12
 7-8
 5-6
 3-4
 0-2

% responses	y8
85	
63	
57	
23	
55	
8	
68	
14	
4	
24	
21	
13	
54	
2	
9	
22	
48	
30	
4	
18	
36	
30	
11	

Subgroup Analyses:

Year 8

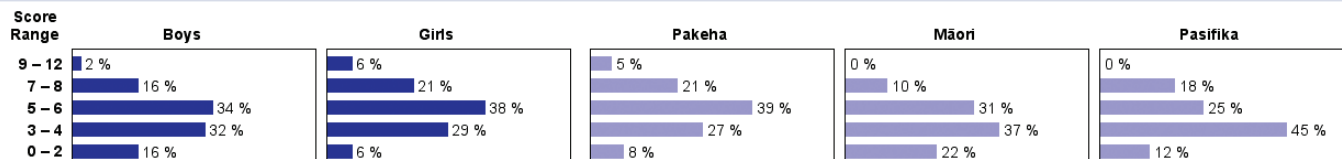

Commentary:

Year 8 students were moderately successful at describing the strengths and weaknesses of classroom furniture. Girls were more successful than boys at this task. It is interesting to see that just over half of the students chose the furniture that would facilitate interaction among students (choice 3).

		% responses	
		y4	y8
LINK TASK: 5			
Approach:	One to one		
Year:	4 & 8		
Focus:	Evaluating designs		
Total score:	15–28	7	31
	12–14	17	32
	9–11	31	27
	6–8	28	7
	0–5	17	2

		% responses	
		y4	y8
LINK TASK: 8			
Approach:	Station		
Year:	4 & 8		
Focus:	Evaluating designs/product analysis		
Total score:	6–11	11	35
	5	18	31
	4	20	15
	3	25	11
	0–2	25	7

		% responses	
		y4	y8
LINK TASK: 6			
Approach:	Station		
Year:	4 & 8		
Focus:	Evaluating design and selecting adaptations		
Total score:	6–7	2	2
	4–5	16	23
	2–3	46	51
	1	21	16
	0	16	7

		% responses	
		y4	y8
LINK TASK: 9			
Approach:	Group		
Year:	4 & 8		
Focus:	Generating and evaluating design solutions		
Total score:	10–12	8	23
	8–9	23	41
	6–7	39	18
	4–5	21	14
	0–3	9	4

		% responses	
		y4	y8
LINK TASK: 7			
Approach:	Station		
Year:	4 & 8		
Focus:	Developing and adapting designs, ideas, solutions		
Total score:	13–31	3	27
	9–12	15	31
	6–8	28	21
	3–5	33	16
	0–2	22	5

		% responses	
		y4	y8
LINK TASK: 10			
Approach:	Team		
Year:	8		
Focus:	Components and processes of systems/ modeling to test design ideas		
Total score:	14–30		36
	11–13		28
	8–10		17
	5–7		13
	0–4		7

5 Technology and Society

Overview: This chapter looks at student responses to tasks that asked them to consider the societal issues and concerns associated with technology. In this area, year 8 students showed substantial growth over year 4 students, particularly in their ability to look at broader issues of societal or family concern with regard to technology. They were more likely to think what age group a toy was appropriate for, or what the consequences of being at sea on a fish processing boat would mean for the families and friends of the workers. On tasks requiring a more straightforward analysis of technology, year 4 and year 8 students were more similar. There was a slight decrease in performance from 2004 for year 4, but no difference at year 8.



Details of the Tasks Administered

The 2008 technology assessment included nine tasks in the area of technology and society. Seven of the tasks were identical for years 4 and 8, and two of the tasks were administered to year 8 students only. Five of the tasks are what we call “trend” tasks. These tasks have been administered in 2004, and comparisons over time can be made with these tasks. Four of the tasks are what we call “link” tasks. We report only basic information in this report, and will re-administer the tasks in 2012 in order to look at trends at that time. Three of the tasks reported on in detail in this chapter are team tasks, where groups of four students participated in the task together, and a single score is reported for the team as a whole.

Comparing Results for Year 4 and Year 8 Students

There are large gains made in performance from year 4 to year 8, particularly in areas that require students to think more broadly about societal aspects of technology. For example, the year 8 students were much more likely to be concerned about social and family aspects of the *Fishing* task (p33). They were more knowledgeable about strengths and weaknesses of cell phones. They were also more likely to consider what age group a particular toy might appeal to, or comment on the decorative features of such toys in addition to their functional characteristics. There were 141 components of tasks that were administered to year 4 and year 8 students. Year 4 students provided correct or strong responses to 24% of these task components, compared to 36% for year 8 students.

Trend Results: Comparing 2004 Results with 2008

There was a slight decline in performance from 2004 to 2008 for the year 4 students, but no change for the year 8 students. Averaged across 104 task components, 26% of year 4 students gave correct or strong responses, compared to 29% in 2004. This represents a slight decrease in performance overall. At year 8, both groups were successful on 38% of the tasks.



Trend Task:

Approach: One to one
 Focus: Managing resources
 Resources: Video on laptop computer, headphones

Year: 4 & 8



DESCRIPTION AND VOICEOVER:

(detailed shots of the processing plant on a commercial fishing vessel.)

A lot of fish can be caught from this boat. All of the processing of the fish is done in the factory on the boat. The tails and heads are chopped off. The machines can be changed to suit the different types of fish that are caught from the boat. The fish are sliced and filleted by the machines. The skins are removed as they stick to the ice-cold rollers.

A lot of people live and work on the boat. They stay on the boat for about six weeks at a time. These people are working together on the production line. They work in teams to keep the fish factory going day and night. They slice the fish ready for weighing and packaging. The fish is frozen and stored on the boat until it is unloaded at a port.

Questions / instructions:

This activity uses the computer.

You are going to watch a video about a fish factory. The fish factory is on a large New Zealand fishing boat.

Click on the **Fishing** button. Ask the following questions after the student has seen the video.

1. How do the machines help the people with their work?

	% response 2008 ('04)	
	year 4	year 8
machines do parts of the processing faster than people could do them	27 (27)	43 (39)
machines do jobs that would be risky for people (e.g. likely to cause injury, OOS (Occupational Overuse Syndrome))	1 (4)	2 (2)
machines do tasks that are very repetitive/boring/unpleasant	9 (7)	9 (10)
machines keep going when people would get tired	3 (6)	4 (1)
machines do some tasks more consistently/accurately/hygenically than people would tend to do them	17 (14)	20 (19)

2. What are the important things that people need to do for the fish factory to work well?

	% response 2008 ('04)	
	year 4	year 8
start their shift on time/punctuality, be there for whole shift	4 (4)	8 (5)
do their own job carefully/thoroughly/safely	14 (13)	23 (24)
keep up with the required pace of work	14 (19)	20 (19)
work/relate well with other workers	32 (31)	48 (43)
maintain and repair the machines to keep them working	12 (7)	17 (14)

3. What are the advantages and the disadvantages of having a fish factory out at sea? Tell me the advantages, or good things, first.

	% response 2008 ('04)	
	year 4	year 8
immediate processing to keep fish fresh	21 (20)	46 (35)
less wasted time travelling out to and in from fishing areas	20 (27)	30 (30)
more fish can be caught	22 (33)	25 (33)

4. Now tell me the disadvantages, or not so good things, about having a fish factory out at sea.

	% response 2008 ('04)	
	year 4	year 8
workers miss friends/family	7 (4)	29 (26)
workers miss activities they would do if home	2 (0)	5 (5)
problems getting on with other workers can be serious because they are constantly together	1 (3)	2 (1)
serious equipment failure can cause greater problems/delays	10 (12)	7 (9)

Overall, student understood and explained the advantages and disadvantages:

very well	0 (0)	0 (0)
quite well	2 (1)	8 (9)
moderately	15 (20)	30 (34)
poorly	83 (80)	62 (57)

Total score:	5-20	13 (11)	37 (32)
	4	9 (15)	15 (15)
	3	16 (24)	19 (24)
	2	25 (18)	17 (13)
	0-1	37 (33)	12 (17)

Subgroup Analyses:

Year 4

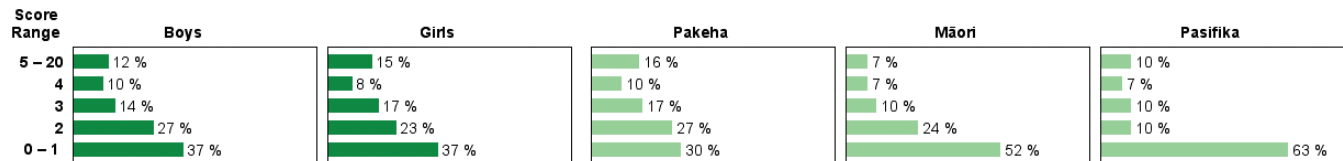

Year 8

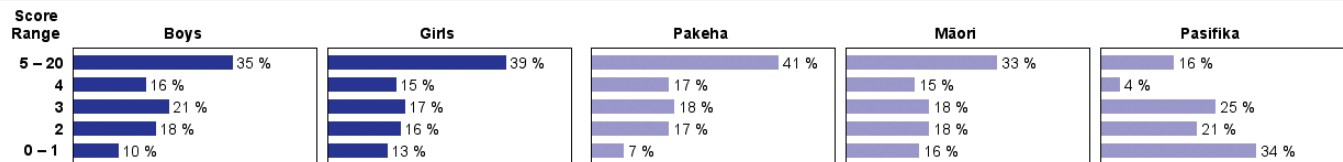

Commentary:

This task asked students to discuss a video they saw on a commercial fish processing boat. Substantial growth in the ability to do this was seen from year 4 to year 8 although, even at year 8, most students had difficulty with the task. Gender differences were minimal; Pakeha students were more successful on the task than Pasifika or Māori students. Performance was similar to 2004.

Approach: One to one
 Focus: Evaluating decisions, strategies, outcomes and consequences
 Resources: 2 pictures

Questions / instructions:

Telephones have changed a lot over time. Here are some pictures of different telephones.

Show picture of different phones.



	% response 2008 ('04)			% response 2008 ('04)	
	year 4	year 8		year 4	year 8
1. Phones and people's lives have changed a lot over time. Tell me about how the technology used in phones has changed.			4. What are some of the not so good things about cell phones?		
Changes mentioned:			people expect you to be available all the time	1 (3)	3 (2)
lighter/smaller/more portable	45 (46)	70 (79)	health dangers (distraction when driving, electromagnetic radiation, etc)	8 (5)	22 (16)
change from cord handsets to cordless handsets	40 (35)	64 (71)	cost (of instrument and use)	28 (30)	41 (60)
change from landline unit to cellular	32 (31)	52 (54)	text bullying	6 (3)	23 (8)
Additional efficiencies:			phone coverage (poor or unavailable in some areas)	6 (8)	18 (11)
(e.g. push buttons, redial, stored numbers)	78 (76)	84 (78)	battery (running low/recharging/battery life)	38 (35)	36 (47)
Non-telephone functions:			5. Why do the people who design and make phones always want to have new ideas?		
(e.g. texting, photos, e-mail, games)	37 (41)	57 (63)	to make money/improve market share	32 (26)	55 (69)
2. How have the changes in telephones changed how people use them?			to improve services for people	16 (23)	40 (32)
able to use them in wider range of places	35 (39)	63 (62)	Overall, how well did student understand and explain?		
able to be contacted a higher proportion of the time/more quickly	4 (3)	19 (21)	very well	2 (0)	10 (13)
texting has partially replaced phoning, e-mail, passing notes	15 (9)	35 (36)	quite well	10 (8)	31 (32)
used for entertainment, visual communication	8 (6)	14 (23)	moderately well	36 (34)	44 (40)
Now let's think just about cell phones.			poorly	52 (58)	16 (15)
Show cell phone picture.			Total score:	13-24	3 (3)
[Same image as cell phone at right above]				10-12	14 (9)
3. What are the good things about cell phones?				7-9	32 (29)
take them with you and use them just about everywhere	59 (54)	75 (83)		4-6	34 (45)
use in safety/security situations	11 (14)	24 (22)		0-3	17 (13)
texting and e-mail capabilities	55 (48)	77 (68)			2 (1)
entertainment device	50 (50)	53 (51)			

Subgroup Analyses:

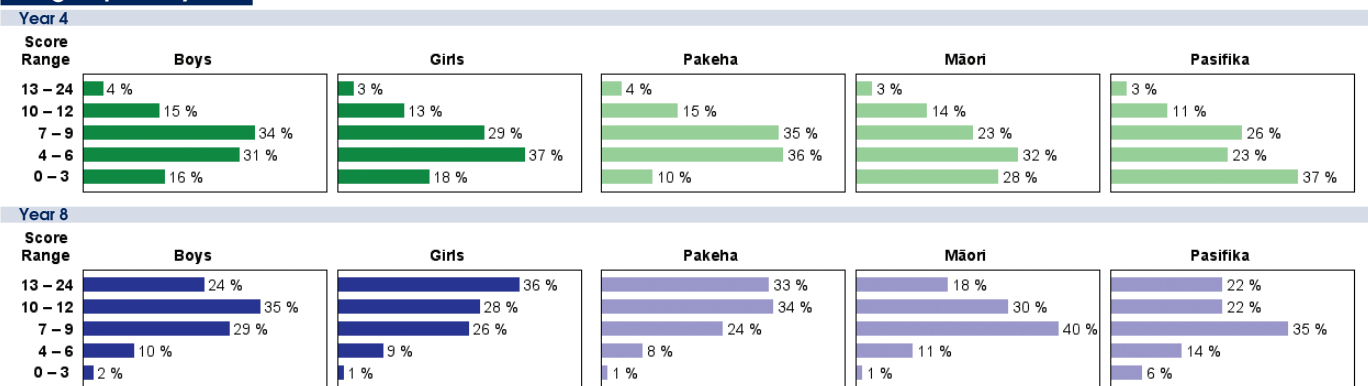

Commentary:

Most students were able to describe how phones have changed over time and identify positive and negative aspects of cell phones. Strong growth was seen from year 4 to year 8. It is interesting to note that, at year 8, the number of students seeing "text bullying" as a not so good thing about cell phones rose from 8% in 2004 to 23% in 2008. There was little change overall from 2004, and modest gender differences favouring girls.

Approach: Team

Focus: Generating possible solutions and related strategies; selecting, developing or adapting solutions

Resources: 4 individual answer sheets, team answer sheet

Questions / instructions:

Imagine that your team is going to set up a pizza factory in your school to help raise funds for a school trip. You would be selling it to the children and teachers in your school. Before you start to make pizzas, you need to have good information. You need to know about the kind of pizza people might want to buy, and the best way to sell it. You would need to get your information from the people who might buy the pizza, so you will need to think of questions to ask them.

To start off, each person in your team will do some thinking on your own. On your own, make up a list of the things that you think might make people want to buy it. See how many things you can think of. I'll give you each a piece of paper to write your list of things on. You can have two or three minutes to do this.

Give each student an answer sheet and supervise independent work.

You've each had a chance to think about things that might make people want to buy the pizza you will make at your factory. It would be a good idea to make up a list of questions, or a survey, so that you can get information from quite a few people; information that would help you to decide what kind of pizza to make, and how you would sell it.

It's time to work as a team now. First, each person is to tell the others the things they thought of that might cause people to want to buy your pizza.

Students read out individual answer sheets.

Now your team is to make up a set of questions, or a survey, that you will use to find out information that will help you decide what kind of pizza to make, and how you would sell it. You can plan and write your questions on the paper, and you can have about 10 minutes to make up your survey. After that you can try out your survey on me, and ask me your questions. Let me know when you are finished.

Give out team answer sheet. Allow up to 10 minutes.

Now you can try out your survey by asking me your questions. I'll tell you what my answers would be.



	% response 2008 ('04)			% response 2008 ('04)	
	year 4	year 8		year 4	year 8
Issues addressed about usual customer behaviour:			Issues addressed about sales and advertising:		
enjoyment of pizza/frequency or volume of pizza consumption	13 (17)	27 (30)	preference for source [commercial vs community] (e.g. fundraising)	3 (3)	3 (7)
eating in restaurant vs eating elsewhere	7 (12)	5 (18)	day of week/time of day preferences	3 (8)	12 (22)
if eating out, pick up vs delivery	17 (20)	14 (28)	desired wait time (for cooking/delivery)	8 (7)	7 (3)
Issues addressed about type of product:			liking for special deals/packages (e.g. cheaper for two, drinks included)	29 (42)	35 (40)
size preferences (and whole vs slices)	34 (33)	49 (52)	best advertising options to attract your attention	15 (20)	24 (32)
type of base preferences	28 (20)	38 (38)	price	31 (40)	71 (76)
topping preferences	92 (90)	92 (95)	Extent to which responses fit survey task:		
ready to eat vs ready to cook	8 (13)	8 (12)	high	0 (2)	5 (13)
presentation preferences (packaging, pre-cutting, etc.)	11 (5)	19 (22)	moderate	19 (35)	43 (30)
side order preferences (drinks, fries, etc.)	29 (38)	32 (32)	low	81 (63)	52 (57)
			Total score:		
			8-17	1 (7)	11 (19)
			6-7	11 (18)	28 (29)
			4-5	32 (27)	33 (36)
			2-3	45 (42)	27 (14)
			0-1	12 (7)	2 (3)

Commentary:

Students had difficulty in developing ideas for a survey on how to sell pizzas to students in their schools. This can be seen particularly for year 4 students, where their overall response was rated as "low" 81% of the time. Year 8 students fared better, but still did not do well. There was a drop off in performance for both years from 2004.

Trend Task: Toys

Approach: Group

Year: 4 & 8

Focus: Investigating and evaluating design

Resources: 5 toys, 4 team badges, 2 pictures, 2 cards, *Working Together* team card (see p50)

Questions / instructions:

Read and explain 'Working Together' card with students.

We are going to look at some toys. Each of you will have a different toy and I will ask you some questions about your toy. Here are the questions I will be asking.

Show and read question card 1, then hand out toys – Goggle Eyes to Student 1, Wendy toy to Student 2, Stethoscope to Student 3 and Robo Insect to Student 4.

[Card 1 same as questions 1-3 below.]



[Student 1] show the others your toy (goggle eyes).

1. Who do you think might like to have this toy?

PROMPT: *Who else?*

Mentions:	Gender –	% response 2008 ('04)	
		year 4	year 8
girls		0 (0)	1 (0)
	boys	11 (19)	5 (14)
age		31 (21)	73 (70)
specific relevant interest		40 (39)	57 (54)

2. Why might they like to have it?

3. What has the toy maker done so they might like to have it?

	% response 2008 ('04)	
	year 4	year 8
decorative features of toy (including colour)	31 (37)	68 (46)
functionality	80 (73)	84 (80)

[Student 2] show the others your toy (Wendy toy).

4. Who do you think might like to have this toy?

PROMPT: *Who else?*

Mentions:	Gender –	% response 2008 ('04)	
		year 4	year 8
girls		7 (11)	6 (8)
	boys	8 (21)	9 (8)
age		66 (66)	88 (84)
specific relevant interest		44 (46)	51 (48)

5. Why might they like to have it?

6. What has the toy maker done so they might like to have it?

	% response 2008 ('04)	
	year 4	year 8
decorative features of toy (including colour)	36 (43)	68 (71)
functionality	52 (64)	67 (61)

[Student 3] show the others your toy (stethoscope).

7. Who do you think might like to have this toy?

PROMPT: *Who else?*

Mentions:	Gender –	% response 2008 ('04)	
		year 4	year 8
girls		2 (9)	0 (4)
	boys	3 (10)	3 (8)
age		37 (37)	77 (75)
specific relevant interest		76 (73)	80 (77)

8. Why might they like to have it?

9. What has the toy maker done so they might like to have it?

	% response 2008 ('04)	
	year 4	year 8
decorative features of toy (including colour)	25 (42)	49 (28)
functionality	59 (59)	62 (63)

[Student 4] show the others your toy (Robo Insect).

10. Who do you think might like to have this toy?

PROMPT: *Who else?*

Mentions:	Gender –	% response 2008 ('04)	
		year 4	year 8
girls		0 (0)	1 (0)
	boys	21 (36)	18 (37)
age		44 (38)	80 (85)
specific relevant interest		30 (31)	51 (39)

11. Why might they like to have it?

12. What has the toy maker done so they might like to have it?

	% response 2008 ('04)	
	year 4	year 8
decorative features of toy (including colour)	34 (42)	66 (56)
functionality	73 (82)	88 (82)

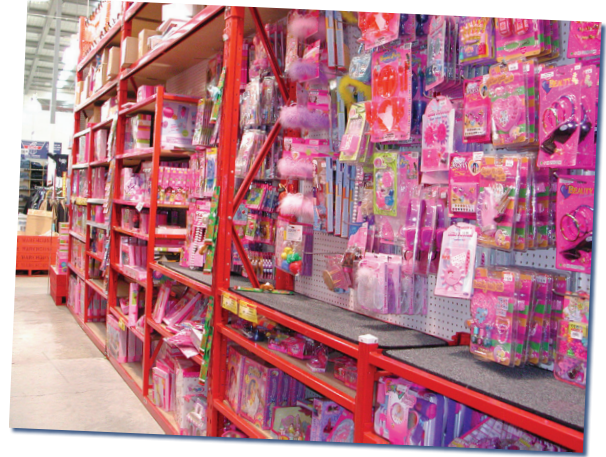

I'm going to give you some pictures of shelves in a toy shop and a teddy bear, then as a group you will talk about the questions on this card.

Read then give students question card 2.
[Card 2 same as questions 1-4 below.]

GROUP DISCUSSION:

Hand out the pictures and the teddy bear.

Talk together for a couple of minutes and try to agree on your answer to each question. After that I'll ask you to tell me your group's answers.

Allow time.

Now tell me your group's answer to each question, starting with question 1.

Students respond.

		% response 2008 ('04)	
		year 4	year 8
1.	Why has the shop arranged its toys in this way? mentions gender	65 (77)	88 (93)
2.	Do you think it is a good idea to arrange the toys in this way? yes	89 (91)	87 (97)
	no	2 (2)	6 (0)
	no agreement	7 (3)	7 (3)
3.	Why do you think that? How strongly did team argument back team choice?		
	strongly	28 (45)	47 (40)
	moderately	49 (35)	42 (48)
	weakly	23 (21)	11 (12)
4.	Where would you put the teddy bear? Why?		
	pink aisle	35 (46)	47 (52)
	red aisle	2 (2)	3 (2)
	another place	29 (32)	36 (40)
	no clear decision	34 (20)	15 (7)
	mentions gender	38 (58)	71 (64)

		% response 2008 ('04)	
		year 4	year 8
Total score:	10-11	2 (0)	22 (19)
	9	7 (14)	21 (23)
	8	18 (27)	29 (16)
	7	14 (25)	15 (23)
	0-6	59 (34)	13 (19)

Commentary:

Substantial gains in performance from year 4 to year 8 were seen in this task asking students to discuss design features of a variety of toys. In particular, older students attended to the decorative features of the toys far more than younger students. In contrast, both groups addressed the functionality of the toys. There was a decline in performance for year 4 students, but not for year 8 students.

Approach: Group

Focus: Managing resources

Resources: 4 pieces of paper, 4 pairs of scissors, 4 rulers, 4 pencils, 4 instruction cards, cue card

Questions / instructions:

Hand each student an instruction card, pencil, paper, ruler and scissors.

You are going to try to make a mock-up of a whirligig by following these instructions. If you need some help, I can help you.

If assistance is required, help students to make the whirligig.

Now you can try out your whirligigs. Stand up and hold them high, with the pointed end facing the floor. Hold them at the bottom of the wings, then drop them.

If the whirligigs do not twirl, adjust the torn strips and have the students drop them again.

Imagine your class has decided to make lots of good quality whirligigs to sell at the school fair. As a group, you are going to discuss how you could do this. This card tells you the things that you will need to think and talk about.

Read cue card to students.

[same questions as 1–4 below.]

After you have talked about your ideas, I'll ask you to tell me what you have decided to do for each of the four questions on the card.

Allow about five minutes for discussion.

Now, tell me what your group decided for each of the four questions.

Ask the team each question from the cue card.

How to Make a Whirligig

- Cut out a strip of paper 15 cm long and 4 cm wide.
- Draw a line 5 cm down from the top of the strip. Make a tear down the middle of the strip to the pencil mark. This is the top of the whirligig.
 
- At the bottom, fold the corners into the middle to make a point. Then fold the sides in again to make a sharp long point.
- Fold one of the torn half strips forward and the other one backward. The strips need to point upwards a little bit. The whirligig should look like a Y shape.

	% response 2008 ('04)			% response 2008 ('04)	
	year 4	year 8		year 4	year 8
1. How could you make the whirligigs so lots of children would want to buy them?			4. What else could your team do so that there are lots of whirligigs to sell? [e.g. order, production line.]		
Mentioned ideas about:			Overall merit of the responses:	high	1 (2) 3 (2)
the general design (e.g. size, shape, structural features)	38 (45)	52 (42)	quite high	16 (19)	21 (7)
the materials used	40 (41)	58 (52)	moderate	35 (41)	43 (33)
decorative features (e.g. colour, printed designs)	93 (95)	99 (95)	low	48 (39)	33 (58)
the performance capabilities of the whirligigs	17 (22)	32 (22)			
the packaging of the whirligigs	11 (9)	8 (7)			
the cost of the whirligigs	41 (35)	38 (43)			
Overall merit of the responses:			Total score:	4–9	32 (22) 32 (14)
high	0 (0)	4 (0)	3	18 (24)	22 (14)
quite high	12 (7)	16 (14)	2	13 (17)	16 (25)
moderate	35 (48)	42 (43)	1	15 (19)	14 (19)
low	53 (45)	38 (43)	0	22 (19)	16 (28)
2. What problems might your team have when trying to make lots of whirligigs for the school fair?					
3. What could your team do to overcome some of these problems?					
Mentioned ideas about:					
availability of suitable personnel	53 (52)	59 (62)			
processes and/or equipment	47 (57)	61 (35)			
supply/storage of materials	54 (71)	69 (60)			
coordination of personnel, resources and processes	61 (53)	68 (67)			
Overall merit of the responses:					
high	0 (0)	3 (3)			
quite high	12 (19)	22 (7)			
moderate	39 (47)	51 (38)			
low	49 (35)	25 (52)			

Commentary:

Students had difficulty in discussing how to make paper whirligigs so that lots of students in their schools would want to buy them. This may have been attributable to the fact that the whirligigs were fairly simple to make, and students may not have seen them as something of value to purchase. Scores at year 4 and at year 8 were quite similar, but there is strong growth from 2004 to 2008.

% responses
y4 y8

LINK TASK: 11

Approach: Station

Year: 4 & 8

Focus: Exploring technological change

Total score:	4–15	4	14
	3	12	21
	2	23	35
	1	42	22
	0	20	9

LINK TASK: 12

Approach: Station

Year: 4 & 8

Focus: Evaluating strategies

Total score:	4–12	3	10
	3	12	25
	2	34	34
	1	39	27
	0	13	4

LINK TASK: 13

Approach: One to one

Year: 8

Focus: Evaluating design

Total score:	9–17	4
	7–8	19
	5–6	36
	3–4	34
	0–2	7

LINK TASK: 14

Approach: Team

Year: 4 & 8

Focus: Designing a survey

Total score:	13	21
	11–12	24
	9–10	32
	7–8	21
	0–6	3

6 Technology Survey

Overview: Technology is highly popular with students at both years, but more so at year 8. The results here are consistent with the findings over the years in NEMP reports that for year 8 students, only physical education is a more popular subject area. This seems particularly relevant at this time as there is a concern among educators in New Zealand about the lack of enthusiasm toward school in general seen by students in years 7 and 8. Technology is a subject area where the enthusiasm remains high. The survey results also show that there is an increase in the use of tools and in the actual designing and making of objects in school at year 8 (as compared to year 4). However, the construction of objects in the home at year 8 shows a decline from 2004, with a concomitant rise in the use of computers.



Attitudes and Motivation

The national monitoring assessment programme recognises the impact of attitudinal and motivational factors on student achievement in individual assessment tasks. Students' attitudes, interests and liking for a subject have a strong bearing on progress and learning outcomes. Students are influenced and shaped by the quality and style of curriculum delivery, the choice of content and the suitability of resources. Other important factors influencing students' achievements are the expectations and support of significant people in their lives, the opportunities and experiences they have in and out of school, and the extent to which they have feelings of personal success and capability.

Technology Survey

The national monitoring technology survey sought information from students about their perceptions of their achievement and potential in technology. Students were also asked about their involvement in technology-related activities within school and beyond. The survey was administered to both year 4 and year 8 students in independent format, with teacher help readily available. Six questions (one in nine parts) asked students to select a response on a three or four-point rating scale. The responses

to these six questions are summarised in the two tables adjacent. The first of the rating questions was unchanged from 1996 and 2000, so comparative figures for the earlier surveys are also presented for that question. The remaining five questions were unchanged from the 2004 survey, and so results are presented from 2004 and 2008

The results show that a majority of year 4 students enjoy doing technology at school, think they are good at it, and want to do more. A large majority (86%) gave a favourable response to the question, "How much do you like technology at school?" This result is up from 81% in 2004, and similar to the 2000 and 1996 results. Students were less enthusiastic about how much they thought they actually learned about technology in school. Slightly less than half thought they learned "heaps" or "quite a lot", almost unchanged from 2004. Only a third thought that they did really good things in technology in school "heaps" or "quite a lot". Three quarters of the students thought they were good at technology and nine out of ten students (90%) wanted to do as much or more technology in school.

When asked to indicate how often they engaged in various technological activities at school (from a list of nine such activities), year 4 students identified





making things and checking how good their ideas were most often, followed by designing things, and changing things to improve them.

Year 8 students are even more enthusiastic about technology in school than year 4 students. Fully 95% of students said they enjoyed technology in school, with 57% giving the highest rating on this question. Additionally, 92% think that they are good at technology, and 96% would like to do the same amount or more technology in school. Like the year 4 students, only 45% believe their class often does really good things in school, however, 72% believe they learn either "heaps" or "quite a lot" about technology in school. The results for 2008 are similar to the results for 2004.

When asked to indicate their perceptions of the frequency of nine different aspects of technological activity at school, year 8 students identified making and designing things, learning how to use tools and equipment, and checking how good their ideas were as the most common activities, followed by changing things to improve them and finding and using information to help make decisions. The pattern of responses is fairly consistent with the 2004 results. It is interesting to note differences here with the year 4 results, particularly in using tools (48% to 80%), and designing things (57% to 81%).

YEAR 4 TECHNOLOGY SURVEY RESPONSES 2008 (2004) [2000] {1996}

1. How much do you like doing technology at school?

			
55 (47) [56] [57]	32 (34) [29] [38]	7 (14) [9] [4]	5 (5) [6] [1]

2. How much do you think you learn about technology at school?

heaps	quite a lot	some	very little
20 (18)	29 (29)	34 (45)	18 (8)

3. Would you like to do more or less technology at school?

more	about the same	less
58 (45)	32 (41)	10 (14)

4. How often does your class do really good things in technology?

heaps	quite a lot	sometimes	never
12 (13)	21 (26)	57 (37)	10 (24)

5. How good do you think you are at technology?





			
32 (23)	42 (49)	18 (19)	7 (9)

6. How often do you do these things in technology at school?

	heaps	quite a lot	sometimes	never
a. think about how technology affects people	16 (18)	24 (26)	42 (39)	17 (17)
b. find and use information to help make decisions	21 (17)	30 (29)	39 (40)	9 (14)
c. make visits or have visitors to help learn about technology	15 (16)	18 (18)	39 (35)	28 (31)
d. design things	31 (35)	26 (26)	30 (27)	13 (12)
e. try to find out what people want, need or like	17 (18)	22 (23)	43 (40)	18 (19)
f. change things to improve them	31 (24)	24 (26)	34 (33)	12 (17)
g. make things	41 (43)	28 (26)	23 (26)	8 (5)
h. learn how to use tools and equipment	24 (25)	24 (20)	34 (35)	18 (20)
i. check how good our ideas or designs are	31 (29)	31 (28)	24 (31)	13 (12)

YEAR 8 TECHNOLOGY SURVEY RESPONSES 2008 (2004) (2000) {1996}

1. How much do you like doing technology at school?

			
57 (55) [57] [45]	38 (37) [36] [48]	4 (6) [6] [6]	0 (2) [1] [1]

2. How much do you think you learn about technology at school?

heaps	quite a lot	some	very little
19 (18)	53 (52)	26 (29)	3 (1)





3. Would you like to do more or less technology at school?

more	about the same	less
56 (46)	40 (49)	4 (5)

4. How often does your class do really good things in technology?

heaps	quite a lot	sometimes	never
9 (11)	36 (36)	50 (42)	5 (11)

5. How good do you think you are at technology?

			
26 (20)	66 (63)	7 (15)	1 (2)

6. How often do you do these things in technology at school?

	heaps	quite a lot	sometimes	never
a. think about how technology affects people	24 (22)	30 (26)	37 (43)	9 (9)
b. find and use information to help make decisions	20 (19)	42 (41)	35 (33)	4 (7)
c. make visits or have visitors to help learn about technology	14 (12)	19 (18)	41 (41)	26 (29)
d. design things	51 (42)	30 (31)	17 (23)	2 (4)
e. try to find out what people want, need or like	14 (15)	36 (31)	43 (43)	8 (11)
f. change things to improve them	30 (26)	37 (36)	29 (32)	5 (6)
g. make things	54 (55)	27 (29)	17 (14)	3 (2)
h. learn how to use tools and equipment	49 (48)	31 (28)	17 (20)	4 (4)
i. check how good our ideas or designs are	32 (26)	36 (39)	29 (30)	3 (5)

The remaining three survey questions were open-ended, inviting students to give written or spoken responses. For each question, the students' responses were categorised into several categories, as indicated on the adjacent page.

What is technology?

At the beginning of the survey, students were asked what they thought technology was. Up to four different responses could be recorded for each student. The table adjacent categorises both year 4 and year 8 responses into eight categories. Comparisons are made to student responses in the 2004 survey. Since this question required coding of answers, somewhat more variability in response over years might be expected as compared to questions where students are simply ticking their preferences.

WHAT IS TECHNOLOGY?	year 4 2008 ('04)	year 8 2008 ('04)
hi-tech equipment/ computers	34 (33)	37 (38)
science	26 (13)	14 (6)
making and designing	19 (18)	24 (36)
learning about equipment	4 (2)	7 (6)
meeting needs, solving problems	4 (4)	13 (11)
inventing	3 (4)	5 (6)
workshop subjects	2 (9)	25 (32)
other appropriate	2 (6)	3 (15)

Some students had trouble answering this open-ended question, with 26% of year 4 students, and 16% of year 8 students not providing a response. Other students were able to come with several ideas about what technology was (thus the year 8 totals sum to more than 100%). Year 4 students felt that technology was the use of hi-tech equipment and computers, designing and making things, and generally some aspect of science. Year 8 students gave similar responses, although they were somewhat more likely to mention workshop subjects (woodworking, cooking, metalworking) and less likely to say science. Patterns of response were roughly similar to 2004, with the exception of science being listed more frequently as being an aspect of technology.

What do you require to be good at technology?

Students were asked "what are three things a person needs to be able to do to be really good at technology?" Their responses were categorised into eight categories and are summarised in the table adjacent.

For both year 4 and year 8 students, the most common responses fell into three categories:

- have lots of knowledge or practise a lot
- good personal, interpersonal and communication skills, such as listening and teamwork
- good at making, building, using equipment, measuring, working with hands

For year 8 students only, having good imagination or ideas was also a quite prominent category.

WHAT IS REQUIRED TO BE GOOD AT TECHNOLOGY?	year 4 2008 ('04)	year 8 2008 ('04)
have lots of knowledge or practise a lot	38 (23)	37 (28)
good personal, interpersonal and communication skills, (e.g. listening, teamwork)	22 (23)	49 (39)
good at making, building, using equipment, measuring, working with hands	17 (29)	18 (38)
good at other appropriate skills	13 (9)	21 (15)
good at using computers	10 (6)	6 (6)
good at science, maths, or other related subjects	7 (9)	9 (5)
good at solving problems	5 (2)	6 (3)
good imagination or ideas	4 (7)	19 (21)

It is interesting to note that in comparison to 2004, "have lots of knowledge or practise a lot" increased substantially in terms of perceived importance, and "good at making building, using equipment..." decreased in perceived importance.



What sort of technology things do you do in your own time – when not at school?

Students were asked what sort of technology things they did in their own time. Their responses were categorised into six categories.

For year 4 students "Construction" was the most popular category with 29% of students responding with a related comment. The next two most popular activities were:

- computer (27%)
- electronics – tv, video, games (21%).

In 2004, the corresponding figures were 41%, 18% and 19%.

For year 8 students, the following four categories received almost identical ratings:

- computers (33%)
- construction (32%)
- electronics – TV, video, games (31%)
- cooking or sewing (31%)

In 2004, the corresponding figures were 24%, 49%, 33% and 38%. The most dramatic shift is away from construction (49% to 32% at year 8, and 41% to 29% at year 4). Picking up most of the difference here appears to be greater computer use.

7 Performance of Subgroups

Overview: Although national monitoring has been designed primarily to present an overall national picture of student achievement, the data collected allow for some reporting on differences among subgroups. Using total scores for each of the tasks, we are able to look at performance for both school and individual levels.

At the school level, the most important factor in terms of relationship to performance is socio-economic status (SES). Students in high decile schools consistently outperform students in low decile schools; students in schools in the middle decile range more often have scores closer to the high decile schools. This pattern tends to occur across all areas that are studied in NEMP. The other school level variables (school size, community size, zone and type of school) tend to only have modest relationships with performance.

At the individual level, there are minimal gender effects, but moderate to large effects for Pakeha/Māori differences, Pakeha/Pasifika differences, and for the predominant language spoken in the home, English, or otherwise. Pakeha students receive higher marks than Māori or Pasifika students, and students whose home language is English receive higher marks than students whose home language is not English.



SCHOOL VARIABLES

Five of the demographic variables related to the schools the students attended. For these five variables, one-way analysis of variance was used to check for statistically significant differences among subgroups within each variable.

Because the number of students included in each analysis was quite large (approximately 450), the statistical tests were quite sensitive to small differences. To reduce the likelihood of attention being drawn to unimportant differences, the critical level for statistical significance for tasks reporting results for individual students was set at $p = .01$ (so that differences this large or larger among the subgroups would not be expected by chance in more than 1% of cases). For tasks administered to teams or groups of students, $p = .05$ was used as the critical

level, to compensate for the smaller numbers of cases in the subgroups. In the report, all “differences” mentioned are statistically significant (to save space, the words “statistically significant” are omitted).



School Size

Results were compared from students in large, medium sized, and small schools (exact definitions were given in *Chapter 1* (p8)).

There was no particular discernible pattern of performance by school size found in the results. For year 4 students, there were differences among the subgroups on three of the 22 tasks, *Exercising Rats* (p23), *Shell Container* (p27), and *Link Task 8* (p31). On *Exercising Rats*, students in large and medium schools outperformed students in small schools, but on *Shell Container* and *Link Task 8*, students in small schools performed best. Students in large schools had higher scores on the survey question concerning how much they learned about technology in schools.

School Type

Results were compared for year 8 students attending full-primary and intermediate schools. There were no differences between these two school types. Results were also compared for year 8 students attending intermediate and year 7–13 schools. Again, no differences were found.

Community Size

Results were compared for students living in communities containing over 100,000 people (main centres), communities containing 10,000 to 100,000 people (provincial cities) and communities containing less than 10,000 people (rural areas).

For year 4 students, there were differences on two of the 22 tasks. On *The Crafty Knife* (p16), students from provincial cities outperformed students from main centres and rural areas. On *Link Task 1* (p20), students from rural areas scored highest, followed by students from provincial cities, and then from main centres. There were no differences on questions of the year 4 *Technology Survey* (p41).

For year 8 students, there were no differences among the three subgroups on any of the 29 tasks. There was a difference on one of the survey questions, with students from rural areas and provincial cities indicating that they would like to do more technology than was indicated by students from main centres.

Zone

Results achieved by students from Auckland, the rest of the North Island, and the South Island were compared.

For year 4 students, there were differences among the three subgroups on four of the 22 tasks: *Changes over Time* (p34), *Exercising Rats* (p23), *Whirligigs* (p38), and *Link Task 3* (p20). On each of these tasks, students from the South Island received higher mean scores than students from Auckland or the rest of the North Island. There were no differences among groups on the year 4 *Technology Survey* (p41).

For year 8 students, there were differences among the three subgroups on three of the 29 tasks: students from the South Island scored highest on *Class Furniture* (p30), *Link Task 5* (p31) and *Link Task 14* (p39). There was one significant difference on the year 8 *Technology Survey* (p41), with students from Auckland scoring highest on the question asking students if they would like to do more technology at school.

Socio-Economic Index

Schools are categorised by the Ministry of Education based on census data for the census mesh blocks where children attending the schools live. The SES index takes into account household income levels and categories of employment. The SES index uses 10 subdivisions, each containing 10% of schools (deciles 1 to 10). For our purposes, the bottom three deciles (1-3) formed the low SES group, the middle four deciles (4-7) formed the medium SES group and the top three deciles (8-10) formed the high SES group. Results were compared for students attending schools in each of these three SES groups.

For year 4 students, there were differences among the three subgroups on 11 of the 22 tasks. It is interesting to note that although the tasks were spread fairly evenly across the three sub-areas of technology, none of the team or group tasks showed any significant differences. Because of the number of tasks showing differences, they are not listed here. Students in high decile schools performed better than students in low decile schools on all 11 tasks. On seven of the 11 tasks,

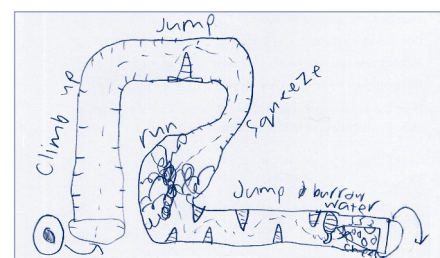

performance of students in the middle decile schools was more similar to the high decile schools than the low decile schools. On the other four tasks, they performed at a level midway between the high and low decile schools. There were no differences by SES on the *Technology Survey* at year 4 (p41).

For year 8 students, there were differences among the three subgroups on 19 of the 29 tasks, spread evenly across the three task chapters. Because of the number of tasks showing differences, they are not listed here. The pattern for 16 of these 19 differences was that the high decile schools received the highest scores, followed by the middle decile schools, followed by the low decile schools. There were no differences on the *Technology Survey* at year 8 (p41).



STUDENT VARIABLES

Three demographic variables related to the students themselves:

- *Gender*: boys and girls
- *Ethnicity*: Māori, Pasifika and Pakeha (this term was used for all other students)
- *Language used predominantly at home*: English and other.

The analyses reported compare the performances of boys and girls, Pakeha and Māori students, Pakeha and Pasifika students, and students from predominantly English-speaking and non-English-speaking homes.

For each of these three comparisons, differences in task performance between the two subgroups are described using “effect sizes” and statistical significance.

For each task and each year level, the analyses began with a t-test comparing the performance of the two selected subgroups and checking for statistical significance of the differences. Then the mean score obtained by students in one subgroup was subtracted from the mean score obtained by students in the other subgroup, and

the difference in means was divided by the pooled standard deviation of the scores obtained by the two groups of students. This computed effect size describes the magnitude of the difference between the two subgroups in a way that indicates the strength of the difference and is not affected by the sample size. An effect size of +.30, for instance, indicates that students in the first subgroup scored, on average, three tenths of a standard deviation higher than students in the second subgroup.

For each pair of subgroups at each year level, the effect sizes of all available tasks were averaged to produce a mean effect size for the curriculum area and year level, giving an overall indication of the typical performance difference between the two subgroups.

Since a number of the tasks administered were team tasks, with mixes of gender, ethnicity and home language in the teams, the number of tasks used for comparison at year 4 is 18, and the number at year 8 is 23.

Gender

For year 4 students, the mean effect size across the 18 tasks was 0.01, with boys scoring slightly higher than girls. This is a negligible difference. There were statistically significant ($p < .01$) differences favouring boys on two of the 18 tasks: *Link Tasks 1 and 2* (p20). Each task had to do with evaluating the design of a product, and boys performed better on both of these tasks. There were no differences on questions of the year 4 *Technology Survey* (p41).

For year 8 students, the mean effect size across the 23 tasks was 0.10, with girls outperforming boys in this instance. Again, this is a small difference in performance. There were significant differences favouring boys on *Link*

Task 4 (p20). There were significant differences favouring girls on six tasks, *Cookie Time* (p17), *Food for Tramping* (p19), *Exercising Rats* (p23), *Class Furniture* (p30) and *Link Tasks 7 and 8* (p31). On the year 8 *Technology Survey* (p41), boys indicated wanting to do more technology in schools than did girls.

It is interesting to note that there was a distinct tendency for boys and girls to perform better on tasks involving technology that has traditionally been linked to gender. This was not the case uniformly, but certainly was a strong trend (e.g. *Cookie Time* (p17) and *Class Furniture* (p30) favouring girls, and *Link Tasks 2 and 4*, involving tool design, favouring boys).



Pakeha-Pasifika Comparisons

Readers should note that only about 30 to 50 Pasifika students were included in the analysis for each task. This is lower than normally preferred for NEMP subgroup analyses, but has been judged adequate for giving a useful indication through the overall pattern of results, of the Pasifika students' performance. Because of the relatively small numbers of Pasifika students, $p = .05$ has been used here as the critical level for statistical significance.

For year 4 students, the mean effect size across the 18 tasks was 0.46 (Pakeha students averaged 0.46 standard deviations higher than Pasifika students). This is a large difference. There were statistically significant differences on 12 of the 18 tasks, with Pakeha students scoring higher on all 12 tasks: *The Crafty Knife* (p16), *Fishing* (p33), *A Bit of a Lemon* (p22), *Fishing Game* (p14), *Changes over Time* (p34), *Cookie Time* (p17), *Bags* (p18) and *Link Tasks 1, 2, 3* (p20), 5 and 6 (p31). There was one difference on the *Technology Survey* (p41), with Pasifika students responding more positively than Pakeha students to the question, "How much do you learn about technology at school?"

For year 8 students, the mean effect size across the 23 tasks was 0.55 (Pakeha students averaged 0.55 standard deviations higher than Pasifika students). This is a large difference. There were statistically significant differences favouring Pakeha students on 19 of the 23 tasks. Because of the number of tasks involved, they will not be listed here. There were no differences on the year 8 *Technology Survey* (p41).

Ethnicity

Results achieved by Māori, Pasifika and Pakeha (all other) students were compared using the effect size procedures. First, the results for Pakeha students were compared to those for Māori students. Second, the results for Pakeha students were compared to those for Pasifika students.



Pakeha-Māori Comparisons

For year 4 students, the mean effect size across the 18 tasks was 0.29 (Pakeha students averaged 0.29 standard deviations higher than Māori students). This is a moderate difference. There were statistically significant differences ($p < .01$) on 10 of the 24 tasks, with Pakeha students scoring higher than Māori students on all 10 tasks: *The Crafty Knife* (p16), *Fishing* (p33), *A Bit of a Lemon* (p22), *Fishing Game* (p14), *Changes over Time* (p34), *Cookie Time* (p17), *Exercising Rats* (p23), and *Link Tasks 2, 3* (p20), and 5 (p31). There was one difference on the *Technology Survey* (p41), with Māori students responding more positively than Pakeha students to the question, "How much do you learn about technology at school?"

For year 8 students, the picture was similar. The mean effect size across the 23 tasks was 0.35 (Pakeha students averaged 0.35 standard deviations higher than Māori students). This is a moderate difference. There were statistically significant differences on 13 of the 23 tasks, with Pakeha students scoring higher than Māori students on all 13 tasks: *A Bit of a Lemon* (p22), *Fishing Game* (p14), *Class Furniture* (p30), *Changes over Time* (p34), *Cookie Time* (p17), *Food for Tramping* (p19), *Exercising Rats* (p23), *Shell Container* (p27), and *Link Tasks 2, 3, 4* (p20) 5 and 7 (p31). There were no differences on the year 8 *Technology Survey* (p41).

Home Language

Results achieved by students who reported that English was the predominant language spoken at home were compared, using the effect size procedures, with the results of students who reported predominant use of another language at home (most commonly an Asian or Pasifika language). Because of the relatively small numbers in the “other language” group, $p = .05$ has been used here as the critical level for statistical significance.

For year 4 students, the mean effect size across the 18 tasks was 0.30 (students for whom English was the predominant language at home averaged 0.30 standard deviations higher than the other students). This is a moderate difference. There were statistically significant differences on 11 of the 18 tasks, with students for whom English was the predominant language spoken at home scoring higher on all 11 tasks: *The Crafty Knife* (p16), *Fishing* (p33), *Fishing Game* (p14), *Changes over Time* (p34), *Cookie Time* (p17), *Bags* (p18) and *Link Tasks 1, 2, 3* (p20), *5* (p31) and *11* (p39). There was one question with a difference on the year 4 *Technology Survey* (p41): students whose predominant home language was English reported doing more really good things in class in technology.

For year 8 students, the mean effect size across the 23 tasks was 0.29 (students for whom English was the predominant language at home averaged 0.29 standard deviations higher than the other students). This is a moderate difference. There were statistically significant differences favouring those whose home language was English on 13 of the 23 tasks. Because of the number of tasks involved, they will not be listed here. There was a question with a difference on the year 8 *Technology Survey* (p41): students whose predominant home language was English reported doing more really good things in class in technology.



Summary, With Comparisons to Previous Technology Assessments

As has been the case for Technology since the 1996 assessments, school type (full-primary, intermediate, high school or other), school size, community size and geographic zone were not important factors predicting achievement on the technology tasks. However, there were statistically significant differences in the performance of students from low, medium and high decile schools on 45% of the tasks at year 4 (compared to 63% in 2004, 86% in 2000, and 27% in 1996), and 66% of the tasks at year 8 (compared to 72% in 2004, 48% in 2000, and 50% in 1996). Thus, we see that SES continues to be an important factor in predicting outcomes in technology, but with no clear trend.

For the comparisons of boys with girls, Pakeha with Māori, Pakeha with Pasifika students, and students for whom the predominant language at home was English with those for whom it was not, effect sizes were used (as described above).

Differences between boys and girls are small, as has been the case in previous assessments. Year 4 boys averaged negligibly higher than girls (mean effect size 0.01), but year 8 girls averaged slightly higher than boys (mean effect size 0.10). The corresponding figures in 2004 were 0.01 at year 4 (boys higher) and 0.07 at year 8 (girls higher). In 2000, the comparable figures were 0.03 at year 4 (boys higher) and 0.03 at year 8 (boys higher).

Pakeha students averaged moderately higher than Māori students, with mean effect sizes of 0.29 for year 4 students and 0.35 at year 8. In 2004, the corresponding numbers were 0.31 (year 4) and 0.36 (year 8). In 2000, the numbers were 0.38 for both year 4 and year 8. The differences here have been quite consistent over the years.

Pakeha students averaged substantially higher than Pasifika students, with mean effect sizes of 0.46 for year 4 students, and 0.55 for year 8 students. The corresponding figures for 2004 were 0.41 (year 4) and 0.45 (year 8). In 2000, the numbers were 0.56 (year 4) and 0.47 (year 8). So, although the differences are slightly larger this year than in the previous assessment, the order of magnitude of differences has been fairly consistent over the assessments.

Students for whom the predominant language at home was English averaged moderately higher than students from homes where other languages predominated, with mean effect sizes of 0.30 for year 4 students and 0.29 for year 8 students. In 2004, the comparable figures were 0.24 for year 4, and 0.33 for year 8. Comparative figures are not available for the assessments in 2000.

A Appendix : The Sample of Schools and Students in 2008



Year 4 and Year 8 Samples

In 2008, 2867 children from 248 schools were in the main samples to participate in national monitoring. About half were in year 4, the other half in year 8. At each level, 120 schools were selected randomly from national lists of state, integrated and private schools teaching at that level, with their probability of selection proportional to the number of students enrolled in the level. The process used ensured that each region was fairly represented. Schools with fewer than four students enrolled at the given level were excluded from these main samples, as were special schools and Māori immersion schools (such as Kura Kaupapa Māori).

In late April 2008, the Ministry of Education provided computer files containing lists of eligible schools with year 4 and year 8 students, organised by region and district, including year 4 and year 8 roll numbers drawn from school statistical returns based on enrolments at 1 March 2008.

From these lists, we randomly selected 120 schools with year 4 students and 120 schools with year 8 students. Schools with four students in year 4 or 8 had about a

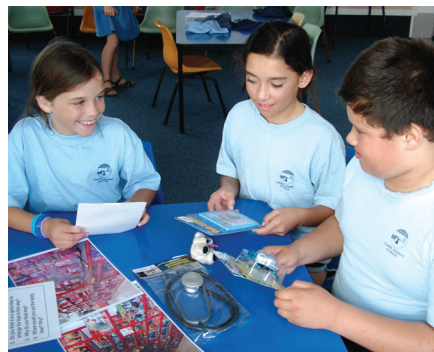

1% chance of being selected, while some of the largest intermediate (year 7 and 8) schools had a more than 90% chance of inclusion.

Pairing Small Schools

At the year 8 level, six of the 120 chosen schools in the main sample had fewer than 12 year 8 students. For each of these schools, we identified the nearest small school meeting our criteria to be paired with the first school. Wherever possible, schools with eight to 11 students were paired with schools with four to seven students, and vice versa. However, the travelling distances between the schools were also taken into account.

Similar pairing procedures were followed at the year 4 level. Here, two pairs of very small schools were included in the sample of 122 schools.

Contacting Schools

In the second week of May, we attempted to telephone the principals or acting principals of all schools in the year 8 sample. In these calls, we briefly explained the purpose of national monitoring, the safeguards for schools and students, and the practical demands that participation would make on schools and students.



We informed the principals about the materials which would be arriving in the school (a copy of a 20-minute NEMP DVD, plus copies for all staff and trustees of the general NEMP brochure and the information booklet for sample schools). We asked the principals to consult with their staff and Board of Trustees and confirm their participation by the middle of June.

A similar procedure was followed at the end of July with the principals of the schools selected in the year 4 samples. They were asked to respond to the invitation within about three weeks.

Response from Schools

Of the 126 schools originally invited to participate at year 8 level, 119 agreed. Two paired schools with four students decreased to one or two students, and were not replaced because their paired school now had close to 12 students. A third paired school with eight students lost some students and was replaced by another small school from the same district. Two large intermediate or middle schools had major building work under way and could not find suitable accommodation for the assessments. Both were replaced by nearby schools

of similar size and decile rating. One integrated college had a key personnel change affecting year 8 arrangements and was replaced by a school of similar character, size and decile rating. Finally, the principal of one independent school indicated that the school had more important priorities. It was replaced by another independent school with the same decile rating.

Of the 122 schools originally invited to participate at year 4 level, 121 agreed. One small primary school's Board of Trustees declined participation because a new principal was being appointed. This school was replaced by a school of similar size and decile rating from the same district.

Sampling of Students

Each school sent a list of the names of all year 4 or year 8 students on their roll. Using computer-generated random numbers, we randomly selected the required number of students (12 or four plus eight in a pair of small schools), at the same time clustering them into random groups of four students. The schools were then sent a list of their selected students and invited to inform us if special care would be needed in assessing any of those children (e.g. children with disabilities or limited skills in English).

For the year 8 sample, we received 123 comments about particular students. In 70 cases, we randomly selected replacement students because the children initially selected had left the school between the time the roll was provided and the start of the assessment programme in the school, or were expected to be away or involved in special activities throughout the assessment week. Two students were replaced because of incorrect classification. The remaining 51 comments concerned children with special needs. Each such child was discussed with the school and a decision agreed. Seven students were replaced because they were very recent immigrants or overseas students who had extremely limited English-language skills. Sixteen students were replaced because they had disabilities or other problems of such seriousness that it was agreed that the students would be placed at risk if they participated. Participation was agreed upon for the remaining 28 students, but a special note was prepared to give additional guidance to the teachers who would assess them.

For the year 4 sample, we received 155 comments about particular students. Fifty-four students originally selected were replaced because they had left the school or were expected to be away throughout the assessment week. Nineteen students were replaced because of their NESB (*Not from English-Speaking Background*) status and very limited English, six because they were in Māori immersion classes, and two because of a wrong year level. Forty-six students were replaced because they had disabilities or other problems of such seriousness the students appeared to be at risk if they participated. Special notes for the assessing teachers were made about 28 children retained in the sample.

Communication with Parents

Following these discussions with the school, Project staff prepared letters to all of the parents, including a copy of the NEMP brochure, and asked the schools to address the letters and mail them. Parents were told they could obtain further information from Project staff (using an 0800 number) or their school principal, and advised that they had the right to ask that their child be excluded from the assessment.

At the year 8 level, we received a number of phone calls including several from students or parents wanting more information about what would be involved. Nine students were replaced because they did not want to participate or their parents did not want them to (usually because of concern about missing regular classwork).

At the year 4 level we also received several phone calls from parents. Some wanted details confirmed or explained (notably about reasons for selection). Two children were replaced at their parents' request.

Practical Arrangement with Schools

On the basis of preferences expressed by the schools, we then allocated each school to one of the five assessment weeks available and gave them contact information for the two teachers who would come to the school for a week to conduct the assessments. We also provided information about the assessment schedule and the space and furniture requirements, offering to pay for hire of a nearby facility if the school was too crowded to accommodate the assessment programme. This proved necessary in several cases.



Results of the Sampling Process

As a result of the considerable care taken, and the attractiveness of the assessment arrangements to schools and children, the attrition from the initial sample was quite low. About 3% of selected schools in the main samples did not participate, and less than 4% of the originally sampled children had to be replaced for reasons other than their transfer to another school or planned absence for the assessment week. The main samples can be regarded as very representative of the populations from which they were chosen (all children in New Zealand schools at the two class levels apart from the 1–2% who were in special schools, Māori immersion programmes, or schools with fewer than four year 4 or year 8 children).

Of course, not all the children in the samples actually could be assessed. Eleven student places in the year 8 sample and two in the year 4 sample were not filled because insufficient students were available in eight small schools. Six year 8 students and nine year 4 students left school at short notice and could not be replaced. Three year 8 students withdrew or were withdrawn by their parents too late to be replaced. Twenty year 8 students and twenty-two year 4 students were absent from school throughout the assessment week. Some other students were absent from school for some of their assessment sessions, and a very small percentage of performances were lost because of malfunctions in the video recording process. Some of the students ran out of time to complete the schedules of tasks. Nevertheless, for most of the tasks over 90% of the sampled students were assessed. Given the complexity of the Project, this is a very acceptable level of participation.

Composition of the Sample

Because of the sampling approach used, regions were fairly represented in the sample, in approximate proportion to the number of school children in the regions.

REGION

PERCENTAGES OF STUDENTS FROM EACH REGION:		
REGION	% YEAR 4 SAMPLE	% YEAR 8 SAMPLE
Northland	4.2	4.2
Auckland	34.1	33.3
Waikato	9.2	10.0
Bay of Plenty/Poverty Bay	8.3	8.3
Hawkes Bay	4.2	3.3
Taranaki	2.5	2.5
Wanganui/Manawatu	5.0	5.8
Wellington/Wairarapa	10.8	10.0
Nelson/Marlborough/West Coast	4.1	4.2
Canterbury	11.7	12.5
Otago	4.2	3.3
Southland	1.7	2.5

DEMOGRAPHY

DEMOGRAPHIC VARIABLES: PERCENTAGES OF STUDENTS IN EACH CATEGORY			
VARIABLE	CATEGORY	% YEAR 4 SAMPLE	% YEAR 8 SAMPLE
Gender	Male	52	52
	Female	48	48
Ethnicity	Pakeha	70	70
	Māori	22	20
	Pasifika	8	10
Main Language at Home	English	87	84
	Other	13	16
Geographic Zone	Greater Auckland	34	33
	Other North Island	44	45
	South Island	22	22
Community Size	< 10,000	18	21
	10,000 – 100,000	19	18
	> 100,000	63	61
School SES Index	Bottom 30%	22	21
	Middle 40%	38	44
	Top 30%	40	35
Size of School	< 25 y4 students	13	
	25 – 60 y4 students	48	
	> 60 y4 students	39	
	<35 y8 students		21
	35 – 150 y8 students		35
Type of School	> 150 y8 students		44
	Full Primary		30
	Intermediate or Middle		48
	Year 7 to 13 High School		12
	Other (<i>not analysed</i>)		10

R Resource Acknowledgements

The National Education Monitoring Project (NEMP) acknowledges the vital support and contribution of the people and organisations who have granted permission for the publication of their work in this report, in the illustration of NEMP assessment resources.

Copyright owners, as listed below, must be contacted directly to negotiate terms and conditions for any use other than that expressly permitted in the publication of NEMP resources and results. Where there is no reference given for a particular resource, the copyright ownership belongs to NEMP.

pg	task	resource	reference
17	Cookie Time	Pictures	(Image sequence from <i>Cookie Time</i> Virtual Tour]. Retrieved March, 2004, from www.cookieotime.co.nz .
26	Eel Trap	Diagram/picture	Faith, R., & Vink, K. (2004). <i>Technology of the Maori: From moa hunter to early European settlement</i> . New Plymouth, New Zealand: Curriculum Concepts.
30	Class Furniture	Desk 1	(Double or quad tote desk.) Retrieved April, 2008, from http://furnware.co.nz/tabid/84/CategoryID/5/ProductID/20/Default.aspx .
		Desk 2	(Royal Student Executive desk.) Retrieved April, 2008, from http://www.teacherssupply.com/products/royalstudentexecdesk-goldenoak/black.htm .
		Desk 3	(3-2-1 desk.) Retrieved April, 2008, from http://furniture@smithsystem.com/productCategory.asp?categoryID=449 .
		Desk 4	(Chair desk.) Retrieved April, 2008, from http://www.furniture4schools.com/product_detail.php?productid=98 .
33	Fishing	Pictures	Television New Zealand. (1999). <i>The Very Best of Country Calendar. Volume 2</i> . N.Z.: TVNZ.

Working Together in a Team

Good Team Members - EVERYONE

- Help everyone to work together.
- Share ideas with others.
- Explain things to each other.
- Listen to each other.
- Stay on the topic.
- Help each other to get the job done.

Team Leader – CHOOSE SOMEONE.
Makes sure everyone is helping and taking turns.

Team Recorder
DECIDE TO CHOOSE SOMEONE, OR TO TAKE TURNS.

- Writes down the team's ideas and decisions.
- Makes sure everyone's ideas are included.
- Writes clearly so that it makes sense.

Team Reporters
DECIDE TO CHOOSE SOMEONE, OR TO TAKE TURNS.

- Listen carefully to what others are saying.
- Understand the team's ideas and decisions.
- Report clearly the team's ideas and decisions.

Technology is a universal and age-old human activity... The technologies used today have built on the ingenuity, traditions, observation and knowledge of people who, throughout history, have sought to improve their lives, solve problems and satisfy their needs and wants.

... a creative, purposeful activity aimed at meeting needs and opportunities through the development of products, systems, or environments. Knowledge, skills and resources are combined to help solve practical problems. Technological practice takes place within, and is influenced by, social contexts.

Technology in the New Zealand Curriculum (1995)



National monitoring provides a “snapshot” of what New Zealand children can do at two levels, at the middle and end of primary education (year 4 and year 8).

The main purposes for national monitoring are:

- to meet public accountability and information requirements by identifying and reporting patterns and trends in educational performance
- to provide high quality, detailed information which policy makers, curriculum planners and educators can use to debate and review educational practices and resourcing.



ISSN 1174-0000

ISBN 1-877182-76-1

